

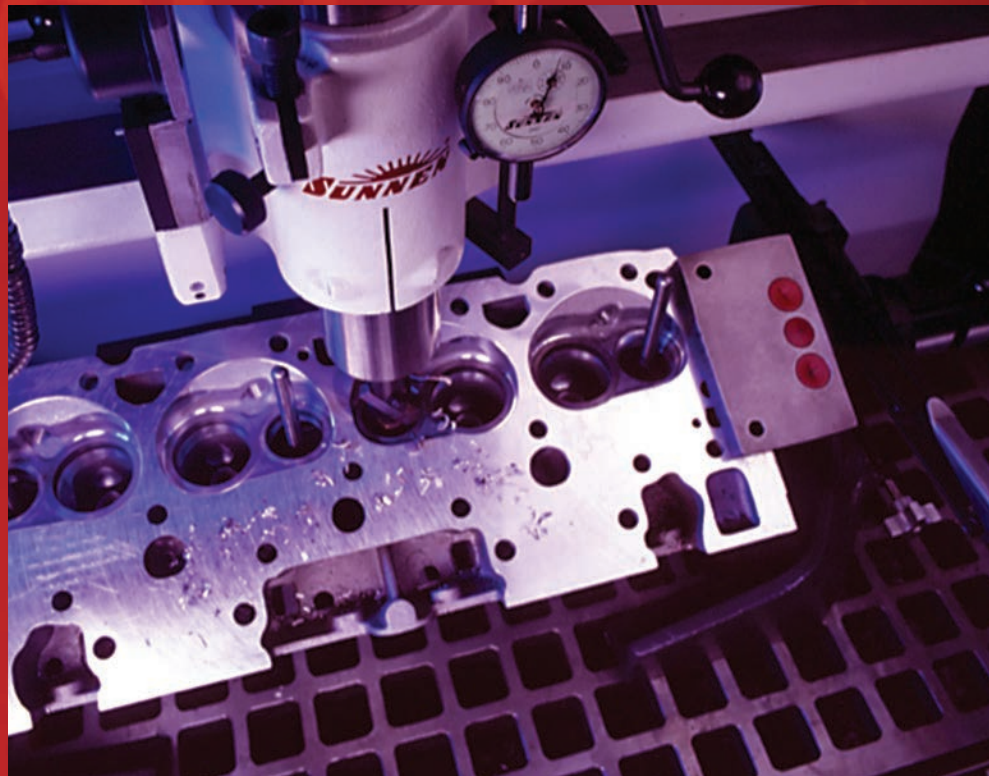

# ENGINE REBUILDING TOOLING AND ACCESSORIES (NON-HONING)

SEAT CUTTERS | GRINDING WHEELS | PILOTS | SURFACING | THERMAL CLEANING



# WE APPRECIATE THE OPPORTUNITY TO SERVE YOU...

## Our Global Commitment

Sunnen began selling machines and accessories internationally shortly after the company was founded in 1924. Headquartered in St. Louis, Missouri, Sunnen's worldwide network includes more than 50 authorized distributors. Sunnen's international facilities extend to Switzerland, Italy, the United Kingdom, Poland, Brazil, Belgium, France, Russia, the Czech Republic and China. We are committed to providing products and services wherever they are needed in the world.

Since its beginning Sunnen has concentrated on the technology of precision honing. Today we are the largest, fully integrated company in this field with more than 500 employees.

In this catalog we have assembled a guide on tooling, accessories and supplies available for non-honing engine rebuilding products. The format makes it easy for you to determine your needs and to order everything required for your operation.

These products include seat cutters, grinding wheels, pilots, surfacing and thermal cleaning. Of course, if you have questions, Sunnen's Customer Service is ready to help. Sunnen takes pride in being an organization of friendly, dedicated people ... committed to serving your needs.

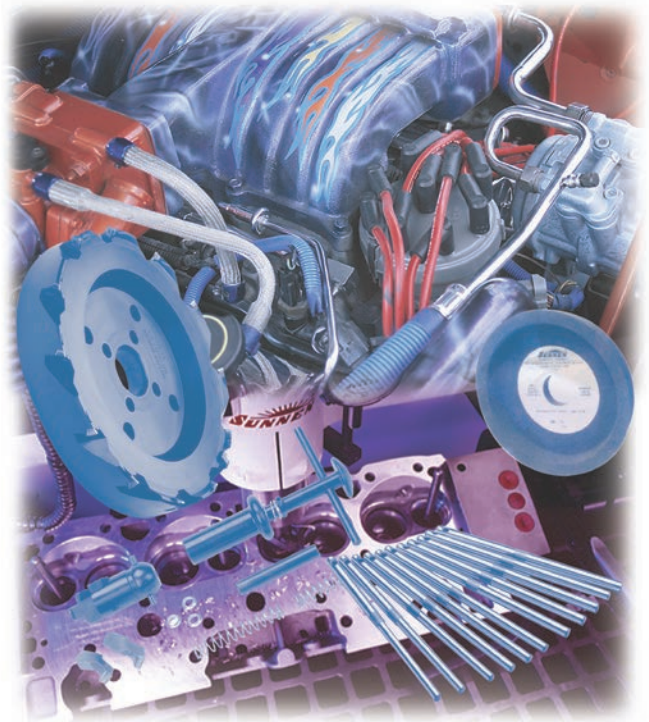



## Technical Expertise – Second to None

Sunnen's Technical Center includes many of the industry's most knowledgeable honing and engine building experts. To ensure superior precision and the highest product quality, no other company in the industry has the extensive complement of high-tech equipment used in the development and testing of machines, tools and abrasives.

## Built and Backed by Sunnen

The Sunnen brand is your assurance of precision and quality. Sunnen tooling and accessories are designed to fit the specific requirements of our equipment ... and to meet the high standards that have made Sunnen Products Company the world leader in honing technology since 1924.



*Sunnen equipment, accessories and supplies are manufactured in our 45,150 sq. meter (486,000 sq. ft.) plant equipped with the most advanced production and quality control systems.*

**If You Have Questions or Need  
Technical Assistance...  
Just Call Toll Free (in the USA):**

**1-800-325-3670**

Customers Outside the U.S.A.,  
please Contact Your Local  
Authorized Sunnen Distributor.

**[sunnen.com](http://sunnen.com)**

# SUNNEN ENGINE HONING MACHINES

**For Nearly 90 Years Sunnen Has Been the Leader in Honing.**

Whether for connecting rods, piston pin bores, cylinder or main bearing bores, we have the right honing system for you.



## **Rod Reconditioning**

Four systems, the **LBB-1660** manual hone, **ML-2000**, **ML-4000** and the **ML-5000** power stroked honing systems offer versatility and accuracy when honing connecting rods.



## **Cylinder Bore Reconditioning**

The **SV-10** and **SV-20** are the standards in the industry for cylinder bore honing in all types of engine blocks.



## **OEM/Production Cylinder Honing**

Sunnen's **SV-2400** Series honing systems are a cost effective solution for production honing applications.



## **Line Honing**

Sunnen's dependable **CH-100** is the best method for fast precision alignment of main bearing bores.

**Sunnen Leads the Way in Engine Rebuilding Equipment with:**

- Abrasives and diamond tooling
- Honing oils and water based coolants
- A nationwide team of factory-trained representatives with solutions to your equipment needs
- Personal customer service for fast, easy ordering
- Technical advice and field service that is second to none

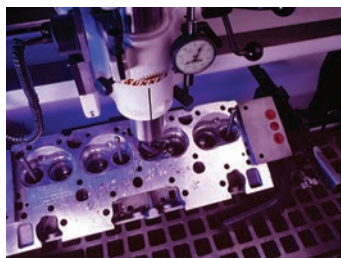

**Table of Contents  
Non-honing Products**

---

<b>Cylinder Head</b> .....	<b>4-42</b>
Valve Refacers .....	4-5
SGM/VGS Tooling & Accessories .....	6-36
CHW 40/50 .....	37
HS-60 .....	38-42

---

<b>Connecting Rod</b> .....	<b>43-44</b>
CRG .....	43
BP-10 Press .....	44

---

<b>Resurfacing</b> .....	<b>45</b>
--------------------------	-----------

---

<b>Thermal Cleaning</b> .....	<b>46</b>
-------------------------------	-----------

For our complete line of honing products see catalog # A-7600.

[sunnen.com](http://sunnen.com)



# VR-6500 Valve Refacer

## Tooling and Accessories for VR-6500 Valve Refacer and TR-6700 Tappet Refacer

**Note: VR Centerless grinders are no longer in production. Supplies and accessories are still available.**

### SCC-100 Coolant Concentrate for VR/TR

(Water Soluble),  
1 Quart (.95 Liters)  
Mix 15 parts water to 1 part concentrate. One quart makes 3.75 gallons (14,2 liters) coolant.



### SCC-101 (1 gallon concentrate)

### COS-155 VR Grinding Coolant

(Mineral Oil Based)  
1 Gallon Pail (3,785 Liters)  
VR and TR coolant tanks require three gallons to fill. Available in 5 gal. Pails. Order COS-155-5 (18,9 liters).



### VR-467A Replacement Diamond Dresser Bit



### Collet Nose Shields



Part No.	Range
VR-273A	.1875"-.3125" (4,75-8,00 mm)
VR-356A	.3125"-.5" (8,00-12,70 mm)
VR-357A	.5"-.75" (12,70-19,05 mm)

### VR Replacement Belts and Pulleys

#### Spindle Drive Belts

PDB-307A (60Hz) prior to S/N 1354  
PDB-307MA (50Hz) prior to S/N 1354  
PDB-325A After S/N 1354

**Jack Shaft Pulley to Collet Spindle Drive Pulley Belt**  
PDB-306A (60Hz)

### VR/TR Grinding Wheels



Part No.	Description
VR-601	Butt
VR-602	General Purpose
VR-603	Titanium
VR-604	Stellite
VR-605	TR-6700 Tappet Grinder Standard Lifters
VR-606	TR-6700 Tappet Grinder Chilled Iron Lifters
VR-607	General Purpose (used with water soluble coolant only)

*For Diamond Wheels for TR Machine, call or write Customer Service and ask for bulletin P-2504.*



# VR Centerless Series

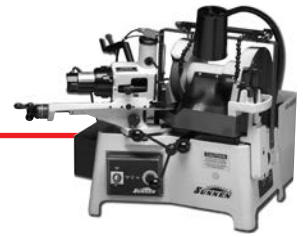

**Note: VR Centerless grinders are no longer in production. Supplies and accessories are still available.**

## VR-7000 and VR-8000 Grinding Wheels



Part No.	Description
VR-1701	Butt
VR-1702	General Purpose (Water)
VR-1703	General Purpose (Oil)
VR-1704	Titanium (Water or Oil)

## VR-1249A Replacement Diamond Dresser Bit (Facing Wheel)



## VR-1238 Replacement Diamond Dresser Bit (Butt Wheel)



## Sunnen VRC-500 Precision Valve Checker

Provides a means of checking the runout of the engine valve face in relation to the valve stem.



### Features: Wide Range of Valve Sizes...

The VRC-500 can accommodate stem diameters from .25 to .75 in. (6-19 mm); head diameters from .625 to 4.5 in. (16-114 mm); and stem lengths up to 9.0 in. long (76 mm). The indicator reads in ten-thousands (.0001 of an inch) increments.

### VRC-500M Metric Checker

Components of the VRC-500M are the same as VRC-500, except the indicator is replaced with a metric indicator calibrated in 0,005 mm increments. The diameter range is .25 to .75 in. (6-19 mm).

## Replacement Roller Assemblies

Part No.	Description
VR-1150A	Left Drive Roller Assembly
VR-1160A	Right Drive Roller Assembly
VR-1155A	Both Right and Left

## Replacement V-Blocks

Part No.	Description
VR-1231A	Adjustable V-Block
VR-1223A	V-Nest (Long)
VR-1224A	V-Nest (Short)

## Replacement Belts and Pulleys

Part No.	Description
VR-1023A	Motor Pulley (60Hz)
PDB-324A	Belt
PDB-204A	Timing Belt



# SGM/VGS Tooling & Accessories

## SGM Single-Blade, 3-Angle Insertable Seat Cutter, Kits & Accessories

**Note: SGM/VGS systems are no longer in production. Supplies and accessories are still available.**

### SGM-700



Features three angle, single blade carbide inserts.  
 Diameter Range: .55 to 1.4 in. (14,0 to 35,5 mm)  
 Seat Width: .060 & .080 in. (1,5 & 2,0 mm)  
 Angles: 38°, 45° & 60°

The Sunnen SGM Seat Angle Cutter Kit is designed for use with Sunnen Valve Seat & Guide Machine, models SGM-1500 and VGS-20.

For Engines with small diameter valves .55-1.4 in. (14,0-35,5 mm).

Kit Includes:

Part No.	Descriptions
<b>SGM-1020</b>	Cutter Body .55-1.4 in. (14,0-35,5 mm)
<b>SGM-1035</b>	Insert Holder Assy .55-.85 in. (14,0-21,5 mm)
<b>SGM-1040</b>	Insert Holder Assy .85-1.4 in. (21,59-35,5 mm)
<b>VSI-A23128</b>	Insert, 38-45-60
<b>VSI-A23228</b>	Insert, 38-45-60
<b>SGM-1200</b>	Pilot Removal Tool
<b>VSC-780</b>	Level Bushing
<b>PSP-212A</b>	Spring, Short & (2) Spring Bushings
<b>PSP-213A</b>	Spring, Long & (2) Spring Bushings
<b>VSC-709A</b>	Spring Bushing (4)
<b>PWMM-7A</b>	Spanner Wrench
<b>SGM-1046</b>	Extension Bushing
<b>SGM-1047</b>	Extension Bushing
<b>PHSM-735A</b>	Fastener (2)

*NOTE: When ordering cutter kit separately, setting fixture SGM-5020 or VSC-400 may be needed. Uses CVP Pilots.*

### Replacement Parts

Part No.	Descriptions	Applications
<b>PHSM-409A</b>	Setscrew (1)	SGM-1040, -1055, -1060
<b>PHSM-410A</b>	Setscrew (1)	SGM-1035, -1045
<b>PHSM-422A</b>	Setscrew (1)	SGM-1065, -1095
<b>SGM-1022A</b>	Locknut	SGM-1025
<b>SGM-1028A</b>	Locknut	SGM-1030
<b>SGM-1039A</b>	Locknut	SGM-1020
<b>PHSM-719A</b>	Screw, T9 (1)	All Holders
<b>PHSM-735A</b>	Screw, M2 (2)	SGM Ext. Bushing
<b>SGM-1046</b>	Ext. Bushing	SGM-1020
<b>SGM-1047</b>	Ext. Bushing	SGM-1020
<b>SGM-1048</b>	Ext. Bushing	SGM-1025
<b>SGM-1049</b>	Ext. Bushing	SGM-1025

### SGM-500



Features three angle, single blade carbide inserts.  
 Diameter Range: 1.0 to 2.50 in. (25,4 to 63,5 mm)  
 Seat Width: .060 & .080 in. (1,5 & 2,0 mm)  
 Angles: 30°, 45° & 60°

The Sunnen SGM Seat Angle Cutter Kit is designed for use with Sunnen Valve Seat & Guide Machine, models SGM-1500 and VGS-20.

Kit Includes:

Part No.	Descriptions
<b>SGM-1025</b>	Cutter Body 1.00-1.56 in. (25,4-39,6 mm)
<b>SGM-1030</b>	Cutter Body 1.50-2.50 in. (38,1-63,5 mm)
<b>VSI-A07840</b>	Insert, 30-45-60
<b>VSI-A12632</b>	Insert, 30-45-60
<b>SGM-1045</b>	Insert Holder Assembly 1.00-1.25 in. (25,4-31,7 mm)
<b>SGM-1055</b>	Insert Holder Assembly 1.20-1.56 in. (30,5-39,6 mm)
<b>SGM-1060</b>	Insert Holder Assembly 1.50-1.94 in. (38,1-49,2 mm)
<b>SGM-1065</b>	Insert Holder Assembly 1.88-2.50 in. (47,6-63,5 mm)
<b>VSC-400</b>	Setting Fixture
<b>PSP-215A</b>	Spring, Short
<b>PSP-216A</b>	Spring, Long
<b>VSC-509A</b>	Spring Bushing (4)
<b>PWMM-8A</b>	Spanner Wrench
<b>PWMM-9A</b>	Spanner Wrench
<b>PWMM-10A</b>	Hex T-Wrench
<b>PHM-419A</b>	Replaceable Tip Screwdriver
<b>PWM-66A</b>	T9 Torx Driver Bit
<b>SGM-1015A</b>	Cutter Body Wrench
<b>PWMM-12A</b>	Hex Wrench
<b>SGM-1048</b>	Extension Bushing
<b>SGM-1049</b>	Extension Bushing
<b>PHSM-735A</b>	Fastener (2)

### SGM-505



Similar to SGM 500, except VSC-400 Setting Fixture is excluded.



# SGM/VGS Tooling & Accessories

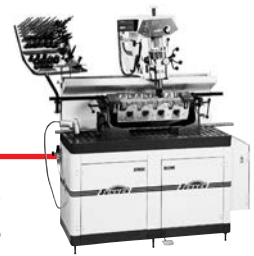

## SGM Single-Blade, 3-Angle Insertable Seat Cutter, Kits & Accessories

### Cutter Bodies SGM-1020

55 to 1.4 in.  
(14,0 - 35,5 mm).  
Uses SVP Pilots.



### Cutter Bodies SGM-1025

1.00 to 1.56 in. (25,4  
- 39,6 mm).  
Uses VS & CP Pilots.



### Cutter Bodies SGM-1030

1.50 to 2.50 in.  
(39,1 - 63,5 mm)  
Uses VS & CP Pilots.



*NOTE: Size range may vary depending upon holder & insert being used.*

### Insert Holders



#### SGM-1035

.55 to .85 in. (14,0 -  
21,59 mm) Cutter.  
Used with SGM-1020.



#### SGM-1040

.85 to 1.40 in. (21,5 -  
35,5 mm) Cutter.  
Used with SGM-1020.

### Insert Holders



#### SGM-1045

1.00 to 1.25 in.  
(25,4 - 31,7 mm) Cutter.  
Used with SGM-1025.



#### SGM-1055

1.20 to 1.56 in.  
(30,5 - 39,6 mm) Cutter.  
Used with SGM-1025.



#### SGM-1090

Used with SGM-1025  
Cutter Body for insert  
angles from 70-79°.



#### SGM-1115

Used with SGM-1025  
Cutter Body for insert  
angles from 80-89°.

### Insert Holders



#### SGM-1060

1.50 to 1.94 in.  
(38,1 - 49,2 mm) Cutter.  
Used with SGM-1030.



#### SGM-1065

1.88 to 2.50 in.  
(47,6 - 63,5 mm) Cutter.  
Used with SGM-1030.



#### SGM-1034PG7X

2.5 to 4.15 in. (63,5 - 105,  
41 mm) Cutter.



#### SGM-1095

Used with SGM-1030  
Cutter Body for insert  
angles from 70-79°.



#### SGM-1125

Used with SGM-1030  
Cutter Body for insert  
angles from 80-89°.

*NOTE: Size range may vary depending upon holder & insert being used.*

### PHSM-719A Torx Drive Insert Screw

Retains the carbide inserts in Insert  
Holder Assemblies (package of 1).



PHSM-719A fits the following Insert Holders:

SGM-1035	SGM-1040	SGM-1045
SGM-1055	SGM-1060	SGM-1065
SGM-1090	SGM-1095	SGM-1115
SGM-1125		

# SGM/VGS Tooling & Accessories

## SGM Single-Blade, 3-Angle Insertable Seat Cutter, Kits & Accessories

### SGM-1015A Cutter Body Wrench



Used along with Spanner Wrench for tightening lock nut on cutter body. Used on SGM-1020, SGM-1025 & SGM-1030 Cutter Bodies.

### Spanner Wrenches

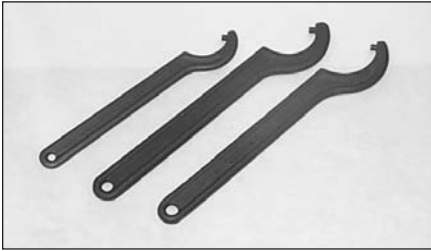

For tightening lock nut on cutter body, to lock insert holder in position.  
 PWMM-7A, for use on SGM-1020  
 PWMM-8A, for use on SGM-1025  
 PWMM-9A, for use on SGM-1030

### SGM-5020

For use with Sunnen SGM Valve Seat



Cutters and ASPC Seat Pocket Cutters. Designed to work with Sunnen VSI Inserts ONLY.

Accurately sets diameters of seat pocket cutters as well as 3-angle seat cutters. Eliminates the guess work involved in locating the seat angle diameter. Easy reading digital scale allows inch/metric conversion and zero setting as well as diameter reading. Resolution .0005 in. (0,01 mm). SR44 battery included.

Kit Includes:

Part No.	Descriptions
<b>SGM-5024</b>	Pilot pin for SGM-1025 and SGM-1030 Bodies
<b>SGM-5027</b>	Pilot pin for SGM-1020 Body
<b>SGM-5023</b>	Pilot pin for ASPC Cutters
<b>SGM-5021</b>	Short spacer stop
<b>SGM-5022</b>	Long spacer stop
<b>SGM-5031</b>	Tool Tray
<b>SGM-5032</b>	Dust Cover
<b>VGS-414</b>	Setting Standard

### PWMM-10A Hex Wrench

2,5 mm Hex Wrench used for adjusting diameter on SGM-1035, SGM-1040, SGM-1045, SGM-1055, SGM-1060, SGM-1065, SGM-1090, SGM-1095, SGM-1115 and SGM-125.

### PHM-419A Replaceable Tip Screwdriver



Screwdriver used for installing Insert Holder Screw. Uses T9 Torx Driver Bit Setting Fixtures

### PWM-66A T9 Torx Driver Bit



# SGM/VGS Tooling & Accessories

## Cutter Inserts - Single Angle

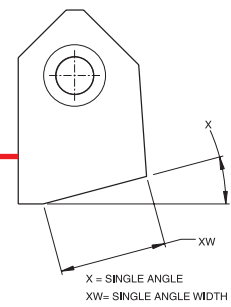

Part Number	Single Angle X	Single Angle Width XW		VSC Number	SERDI Number	NEWEN Number
		mm	in.			
VSI-A14200	5	9,80	0.39	N/A	N/A	WA1-NWN5
VSI-A14300	15	8,50	0.33	VSC-15	15-A1	WA1-NWN15
VSI-A14400	20	8,20	0.32	VSC-20	20-A1	WA1-NWN20
VSI-A14500	25	8,50	0.33	N/A	N/A	WA1-NWN25
VSI-A14600	30	9,00	0.35	VSC-30	30-A1	WA1-NWN30
VSI-A14700	31	8,70	0.34	N/A	N/A	WA1-NWN31
VSI-A14800	37	9,30	0.37	N/A	N/A	WA1-NWN37
VSI-A22300	37.5	9,75	0.38	VSC-375	N/A	N/A
VSI-A22900	38	9,75	0.38	XVSC-38	N/A	N/A
VSI-A23000	39	9,75	0.38	XVSC-39	N/A	N/A
VSI-A14900	45	8,90	0.35	VSC-45	45-A1	WA1-NWN45
VSI-A16000	45.2	8,00	0.31	N/A	45.15-A1	N/A
VSI-A15000	60	8,10	0.32	VSC-60	60-A1	WA1-NWN60
VSI-A15100	70	7,70	0.30	N/A	N/A	WA1-NWN70
VSI-A15200	75	7,00	0.28	VSC-75	N/A	WA1-NWN75
VSI-A15300	78	7,30	0.29	N/A	N/A	WA1-NWN78
VSI-A15400	82	7,07	0.28	N/A	N/A	WA1-NWN82
VSI-A23700	55	8,50	0.33	N/A	N/A	N/A

Inserts for Serdi/Newen Tooling may be ordered by placing an "S" after the Sunnen part number.

Example: VSI-A07840 • VSI-A07840S  
(Sunnen) (Serdi/Newen)

### Special Angle

Special bowl cutters from 70-89° are available on a special order basis. Call for pricing and delivery.

### Bowl Hog Cutters SGM-1075



Used with Sunnen's SGM Cutter Heads to enlarge the bowl area below the valve seat for increased air flow or installation of larger diameter valves. The single-blade, 75° cutter features a .38 in. (9,65 mm) radius at the bottom to blend machined areas and provide a chatter free finish. Cutter easily adjusts to a wide range of diameters eliminating the need for multiple fixed diameter cutters.

### SGM-1082



A single-blade, 82° cutter to enlarge bowl area.

Used with Sunnen's SGM Cutter Heads to enlarge the bowl area below the valve seat for increased air flow or installation of larger diameter valves. The single-blade, 82° cutter features a .38 in. (9,65 mm) radius at the bottom to blend machined areas and provide a chatter free finish. Cutter easily adjusts to a wide range of diameters eliminating the need for multiple fixed diameter cutters.



# SGM/VGS Tooling & Accessories

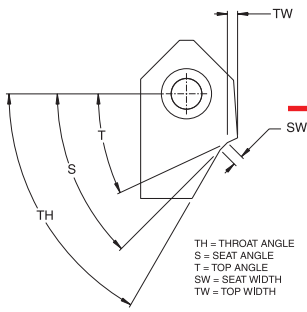

## Cutter Inserts – Three Angle

Inserts for Serdi/Newen Tooling may be ordered by placing an “S” after the Sunnen part number.  
Example: VSI-A07840 • VSI-A07840S  
(Sunnen) (Serdi/Newen)

SUNNEN Part Number	Top T	Angle Seat S	Throat TH	Width				Minimum Diameter	VSC Number	SERDI Number	NEWEN Number	
				Seat SW		Top TW						
				mm	in.	mm	in.					
VSI-A20050	15	30	60	1,00	0.039	2,50	0.098	24,39	0.960	VSC-04030	10K30U60	N/A
VSI-A01332	20	30	52	1,00	0.039	1,60	0.063	25,39	1.000	N/A	10H30D52-A1	WA1-NWN3062
VSI-A22028	23	30	52	1,00	0.039	1,40	0.055	25,39	1.000	VSC7-04030	N/A	N/A
VSI-A00820	15	30	45	1,30	0.051	1,00	0.039	25,39	1.000	N/A	13E30U45-A1	WA1-NWN3023
VSI-A01240	15	30	60	1,30	0.051	2,00	0.079	25,39	1.000	N/A	13K30U60-A1	WA1-NWN3061
VSI-A01540	15	30	45	1,30	0.051	2,00	0.079	25,39	1.000	N/A	13K30U45-A1	WA1-NWN3065
VSI-A00128	15	30	60	1,50	0.059	1,40	0.055	25,39	1.000	N/A	15G30U60-A1	WA1-NWN2152
VSI-A00236	15	30	60	1,50	0.059	1,80	0.071	25,39	1.000	N/A	15J30U60-A1	WA1-NWN2153
VSI-A00736	15	30	52	1,50	0.059	1,80	0.071	25,39	1.000	N/A	15J30U52-A1	WA1-NWN3016
VSI-A01436	15	30	45	1,50	0.059	1,80	0.071	25,39	1.000	N/A	15J30U45-A1	WA1-NWN3064
VSI-A01728	15	30	45	1,50	0.059	1,40	0.055	25,39	1.000	N/A	15G30U45-A1	WA1-NWN3068
VSI-A02740	15	30	60	1,50	0.059	2,00	0.079	25,39	1.000	VSC-06030	15K30U60-A1	WA1-NWN3200
VSI-A22128	23	30	52	1,50	0.059	1,40	0.055	25,39	1.000	VSC7-06030	N/A	N/A
VSI-A01640	15	30	60	1,60	0.063	2,00	0.079	25,39	1.000	N/A	16K30U60-A1	WA1-NWN3067
VSI-A01924	15	30	45	1,60	0.063	1,20	0.047	25,39	1.000	N/A	16F30U45-A1	WA1-NWN3078
VSI-A02236	15	30	45	1,60	0.063	1,80	0.071	25,39	1.000	N/A	16J30U45-A1	WA1-NWN3194
VSI-A02336	15	30	52	1,60	0.063	1,80	0.071	25,39	1.000	N/A	16J30U52-A1	WA1-NWN3195
VSI-A02944	15	30	60	1,60	0.063	2,20	0.087	24,99	0.984	N/A	16L30U60-A1	N/A
VSI-A01028	15	30	60	1,80	0.071	1,40	0.055	25,39	1.000	N/A	18G30U60-A1	WA1-NWN3027
VSI-A02140	15	30	45	1,80	0.071	2,00	0.079	25,39	1.000	N/A	18K30U45-A1	WA1-NWN3146
VSI-A00636	15	30	60	1,90	0.075	1,80	0.071	25,39	1.000	N/A	19J30U60-A1	WA1-NWN3010
VSI-A01140	15	30	60	1,90	0.075	2,00	0.079	25,39	1.000	N/A	19K30U60-A1	WA1-NWN3029
VSI-A01820	15	30	45	1,90	0.075	1,00	0.039	25,39	1.000	N/A	19E30U45-A1	WAI -NWN3072
VSI-A00328	15	30	60	2,00	0.079	1,40	0.055	25,39	1.000	N/A	20G30U60-A1	WAI -NWN2202
VSI-A00940	15	30	45	2,00	0.079	1,60	0.063	25,39	1.000	N/A	16K30U45-A1	WAI -NWN3026
VSI-A02040	15	30	45	2,00	0.079	2,00	0.079	25,39	1.000	N/A	20K30U45-A1	WAI -NWN3084
VSI-A02424	15	30	45	2,00	0.079	1,20	0.047	25,39	1.000	N/A	20F30U45-A1	WAI -NWN3196
VSI-A20138	15	30	60	2,00	0.079	1,90	0.075	25,39	1.000	VSC-08030	20K30U45	N/A
VSI-A22228	23	30	52	2,00	0.079	1,40	0.055	25,39	1.000	VSC7-08030	N/A	N/A
VSI-A02540	15	30	60	2,20	0.087	2,00	0.079	25,39	1.000	N/A	22K30U60-A1	WA1-NWN3198
VSI-A00428	15	30	60	2,50	0.098	1,40	0.055	25,39	1.000	N/A	25G30U60-A1	WA1-NWN2252
VSI-A00528	15	30	60	3,00	0.118	1,40	0.055	25,39	1.000	N/A	30G30U60-A1	WA1-NWN2302
VSI-A02660	20	30	45	3,80	0.150	3,00	0.118	23,39	0.921	N/A	38Q30D45-A1	WA1-NWN3199
VSI-A03030	2	30.5	75	1,50	0.059	1,50	0.059	25,39	1.000	N/A	N/A	WA1-NWN5364
VSI-A03328	15	31	60	1,20	0.047	1,40	0.055	25,39	1.000	N/A	12G31U60-A1	WA1-NWN5362
VSI-A03228	11	31	60	1,50	0.059	1,40	0.055	25,39	1.000	N/A	15G31B60-A1	WA1-NWN5280
VSI-A03440	2	31	60	2,10	0.083	2,00	0.079	25,39	1.000	N/A	21K31S60-A1	WA1-NWN5363
VSI-A22828	25	37.5	75	1,50	0.059	1,40	0.055	25,39	1.000	VSC-532	N/A	N/A
VSI-A03728	30	37.5	60	1,60	0.063	1,40	0.055	25,39	1.000	N/A	16G37.5X60-A1	WA1-NWN5414
VSI-A03840	30	37.5	60	1,60	0.063	2,00	0.079	25,39	1.000	N/A	16K37.5X60-A	WA1-NWN5415
VSI-A23340	25	45.15	52	1,60	0.063	2,00	0.079	25,39	1.000	N/A	16K45.15V52-A1	N/A
VSI-A23436	25	45.15	52	2,30	0.091	1,80	0.071	25,39	1.000	N/A	23,45.15V52-A1	N/A
VSI-A23829	15	45.15	60	2,00	0.079	1,45	0.057	25,29	0.996	N/A	352001-A1	N/A

# SGM/VGS Tooling & Accessories

## Cutter Inserts – Three Angle

SUNNEN Part Number	Top T	Angle Seat S	Throat TH	Width				Minimum Diameter		VSC Number	SERDI Number	NEWEN Number
				Seat SW		Top TW						
				mm	in.	mm	in.	mm	in.			
VSI-A03524	20	37.5	52	1,80	0.071	1,20	0.047	25,39	1.000	N/A	18F37.5D52-A1	WA1-NWN5006
VSI-A03928	30	37.5	60	1,90	0.075	1,40	0.055	25,39	1.000	N/A	19G37.5X60-A1	WA1-NWN5416
VSI-A04040	30	37.5	60	2,00	0.079	2,00	0.079	25,39	1.000	N/A	20K37.5X60-A1	WA1-NWN5417
VSI-A04112	18	37.5	52	2,10	0.083	0,60	0.024	25,39	1.000	N/A	21G37.5C52-A1	WA1-NWN5418
VSI-A08020	32	45	60	0,80	0.031	1,00	0.039	25,39	1.000	N/A	N/A	WA1-NWN4183
VSI-A21128	15	45	60	1,00	0.039	1,40	0.055	25,39	1.000	VSC4-04045	N/A	N/A
VSI-A21736	20	45	75	1,00	0.039	1,80	0.071	25,39	1.000	VSC6-04045	N/A	N/A
VSI-A04220	25	45	60	1,00	0.039	1,00	0.039	25,39	1.000	N/A	10E45V60-A1	WA1-NWN1101
VSI-A04328	25	45	60	1,00	0.039	1,40	0.055	25,39	1.000	N/A	10G45V60-A1	WA1-NWN1102
VSI-A04436	25	45	60	1,00	0.039	1,80	0.071	25,39	1.000	N/A	10J45V60-A1	WA1-NWN1103
VSI-A04560	25	45	60	1,00	0.039	3,00	0.118	23,39	0.921	N/A	10Q45V60-A1	WA1-NWN1105
VSI-A20228	25	45	60	1,00	0.039	1,40	0.055	25,39	1.000	VSC1-04045	N/A	N/A
VSI-A05424	30	45	60	1,00	0.039	1,20	0.047	25,39	1.000	N/A	10F45X60-A1	WA1-NWN4028
VSI-A07136	30	45	60	1,00	0.039	1,80	0.071	25,39	1.000	N/A	10J45X60-A1	WA1-NWN4090
VSI-A09040	30	45	60	1,00	0.039	2,00	0.079	25,39	1.000	VSC-04045	10K45X60-A1	WA1-NWN4303
VSI-A21426	30	45	75	1,00	0.039	1,30	0.051	25,39	1.000	VSC5-04045	10H45X75	N/A
VSI-A05532	35	45	52	1,00	0.039	1,60	0.063	25,39	1.000	N/A	10H45F52-A1	WA1-NWN4029
VSI-A05632	35	45	55	1,00	0.039	1,60	0.063	25,39	1.000	N/A	10H45F55-A1	WA1-NWN4030
VSI-A05732	35	45	60	1,00	0.039	1,60	0.063	25,39	1.000	N/A	10H45F60-A1	WA1-NWN4031
VSI-A20524	38	45	52	1,00	0.039	1,20	0.047	25,39	1.000	VSC2-04045	N/A	N/A
VSI-A20832	38	45	65	1,00	0.039	1,60	0.063	25,39	1.000	VSC3-04045	N/A	N/A
VSI-A07924	30	45	60	1,20	0.047	1,20	0.047	25,39	1.000	N/A	12F45X60-A1	WA1-NWN4182
VSI-A05820	30	45	60	1,30	0.051	1,00	0.039	25,39	1.000	N/A	13E45X60-A1	WA1-NWN4032
VSI-A06040	30	45	52	1,30	0.051	2,00	0.079	25,39	1.000	N/A	13K45X52-A1	WA1-NWN4034
VSI-A06140	30	45	60	1,30	0.051	2,00	0.079	25,39	1.000	N/A	13K45X60-A1	WA1-NWN4035
VSI-A08224	30	45	60	1,30	0.051	1,20	0.047	25,39	1.000	N/A	13F45X60-A1	WA1-NWN4221
VSI-A09932	30	45	60	1,30	0.051	1,60	0.063	25,39	1.000	N/A	13H45X60-A1	WA1-NWN4480
VSI-A05940	37	45	52	1,30	0.051	2,00	0.079	25,39	1.000	N/A	13K45G52-A1	WA1-NWN4033
VSI-A06220	30	45	60	1,40	0.055	1,00	0.039	25,39	1.000	N/A	14E45X60-A1	WA1-NWN4036
VSI-A07240	30	45	60	1,40	0.055	2,00	0.079	25,39	1.000	N/A	41065-A1	WA1-NWN4093
VSI-A05240	15	45	60	1,50	0.059	2,00	0.079	25,39	1.000	N/A	15K45U60-A1	WA1-NWN4015
VSI-A05336	15	45	60	1,50	0.059	1,80	0.071	25,39	1.000	N/A	15J45U60-A1	WA1-NWN4025
VSI-A21228	15	45	60	1,50	0.059	1,40	0.055	25,39	1.000	VSC4-06045	N/A	N/A
VSI-A21828	20	45	75	1,50	0.059	1,40	0.055	25,39	1.000	VSC6-06045	N/A	N/A
VSI-A02828	25	45	60	1,50	0.059	1,40	0.055	25,39	1.000	N/A	15G30U60-A1	WA1-NWN4003
VSI-A08428	25	45	52	1,50	0.059	1,40	0.055	25,39	1.000	N/A	15G45V52-A1	WA1-NWN4241
VSI-A20328	25	45	60	1,50	0.059	1,40	0.055	25,39	1.000	VSC1-06045	N/A	N/A
VSI-A06436	30	45	60	1,50	0.059	1,80	0.071	25,39	1.000	N/A	15J45X60-A1	WA1-NWN4038
VSI-A07036	30	45	52	1,50	0.059	1,80	0.071	25,39	1.000	N/A	15J45X52-A1	WA1-NWN4077
VSI-A07320	30	45	60	1,50	0.059	1,00	0.039	25,39	1.000	N/A	15E45X60-A1	WA1-NWN4094
VSI-A07840	30	45	60	1,50	0.059	2,00	0.079	25,39	1.000	VSC-06045	15K45X60-A1	WA1-NWN4177
VSI-A08128	30	45	60	1,50	0.059	1,40	0.055	25,39	1.000	N/A	15G45X60-A1	WA1-NWN4216
VSI-A12460	30	45	60	1,50	0.059	3,00	0.118	23,39	0.921	N/A	15Q45X60-A1	N/A
VSI-A21526	30	45	75	1,50	0.059	1,30	0.051	25,39	1.000	VSC5-06045	15H45X75	N/A
VSI-A06336	37	45	52	1,50	0.059	1,80	0.071	25,39	1.000	N/A	15J45G52-A1	WA1-NWN4037
VSI-A20624	38	45	52	1,50	0.059	1,20	0.047	25,39	1.000	VSC2-06045	N/A	N/A
VSI-A20924	38	45	65	1,50	0.059	1,20	0.047	25,39	1.000	VSC3-06045	N/A	N/A
VSI-A07440	15	45	60	1,60	0.063	2,00	0.079	25,39	1.000	N/A	16K45U60-A1	WA1-NWN4117
VSI-A10032	15	45	60	1,60	0.063	1,60	0.063	25,39	1.000	N/A	16H45U60-A1	WA1-NWN4481
VSI-A04620	25	45	60	1,60	0.063	1,00	0.039	25,39	1.000	N/A	16E45V60-A1	WA1-NWN1161
VSI-A04728	25	45	60	1,60	0.063	1,40	0.055	25,39	1.000	N/A	16G45V60-A1	WA1-NWN1162
VSI-A04836	25	45	60	1,60	0.063	1,80	0.071	25,39	1.000	N/A	16J45V60-A1	WA1-NWN1163
VSI-A06520	30	45	60	1,60	0.063	1,00	0.039	25,39	1.000	N/A	16E45X60-A1	WA1-NWN4039
VSI-A06640	30	45	60	1,60	0.063	2,00	0.079	25,39	1.000	N/A	16K45X60-A1	WA1-NWN4040

# SGM/VGS Tooling & Accessories

## Cutter Inserts – Three Angle

SUNNEN Part Number	Top T	Angle Seat S	Throat TH	Width				Minimum Diameter		VSC Number	SERDI Number	NEWEN Number
				Seat SW		Top TW		mm	in.			
				mm	in.	mm	in.					
VSI-A07524	30	45	52	1,60	0.063	1,20	0.047	25,39	1.000	N/A	16F45X52-A1	WA1-NWN4135
VSI-A07624	30	45	60	1,60	0.063	1,20	0.047	25,39	1.000	N/A	16F45X60-A1	WA1-NWN4136
VSI-A08660	30	45	60	1,60	0.063	3,00	0.118	23,39	0.921	N/A	16Q45X60-A1	WA1-NWN4258
VSI-A08740	30	45	52	1,60	0.063	2,00	0.079	25,39	1.000	N/A	16K45X52-A1	WA1-NWN4266
VSI-A09432	30	45	60	1,60	0.063	1,60	0.063	25,39	1.000	N/A	16H45X60-A1	WA1-NWN4343
VSI-A09636	30	45	52	1,60	0.063	1,80	0.071	25,39	1.000	N/A	16J45X52-A1	WA1-NWN4361
VSI-A09728	30	45	60	1,60	0.063	1,40	0.055	25,39	1.000	N/A	16G45X60-A1	WA1-NWN4391
VSI-A10132	30	45	52	1,60	0.063	1,60	0.063	25,39	1.000	N/A	16H45X52-A1	WA1-NWN4482
VSI-A09836	32	45	55	1,70	0.067	1,80	0.071	25,39	1.000	N/A	17J45E65-A1	WA1-NWN4479
VSI-A06732	30	45	60	1,80	0.071	1,60	0.063	25,39	1.000	N/A	18H45X60-A1	WA1-NWN4041
VSI-A10260	30	45	60	1,80	0.071	3,00	0.118	23,39	0.921	N/A	18Q45X60-A1	WA1-NWN4483
VSI-A08836	25	45	52	1,90	0.075	1,80	0.071	25,39	1.000	N/A	19J45V52-A1	WA1-NWN4271
VSI-A06840	30	45	60	1,90	0.075	2,00	0.079	25,39	1.000	N/A	19K45X60-A1	WA1-NWN4042
VSI-A07736	30	45	52	1,90	0.075	1,80	0.071	25,39	1.000	N/A	19J45X52-A1	WA1-NWN4146
VSI-A08924	30	45	52	1,90	0.075	1,20	0.047	25,39	1.000	N/A	19F45X52-A1	WA1-NWN4299
VSI-A09124	30	45	60	1,90	0.075	1,20	0.047	25,39	1.000	N/A	19F45X60-A1	WA1-NWN4306
VSI-A09332	30	45	60	1,90	0.075	1,60	0.063	25,39	1.000	N/A	19H45X60-A1	WA1-NWN4339
VSI-A10340	30	45	52	1,90	0.075	2,00	0.079	25,39	1.000	N/A	19K45X52-A1	WA1-NWN4484
VSI-A21328	15	45	60	2,00	0.079	1,40	0.055	25,39	1.000	VSC4-08045	N/A	N/A
VSI-A21928	20	45	75	2,00	0.079	1,40	0.055	25,39	1.000	VSC6-08045	N/A	N/A
VSI-A04928	25	45	60	2,00	0.079	1,40	0.055	25,39	1.000	N/A	20G45V60-A1	WA1-NWN1202
VSI-A20428	25	45	60	2,00	0.079	1,40	0.055	25,39	1.000	VSC1-08045	N/A	N/A
VSI-A05130	30	45	60	2,00	0.079	1,50	0.059	25,39	1.000	N/A	42001-A1	WA1-NWN4006
VSI-A06924	30	45	60	2,00	0.079	1,20	0.047	25,39	1.000	N/A	20F45X60-A1	WA1-NWN4043
VSI-A08332	30	45	70	2,00	0.079	1,60	0.063	25,39	1.000	N/A	20H45X70-A1	WA1-NWN4236
VSI-A09236	30	45	55	2,00	0.079	1,78	0.07	25,23	0.993	N/A	N/A	WA1-NWN4338
VSI-A10432	30	45	75	2,00	0.079	1,60	0.063	25,39	1.000	VSC5-08045	20H45X75-A1	WA1-NWN4485
VSI-A12632	30	45	60	2,00	0.079	1,60	0.063	25,39	1.000	VSC-08045	20H45X60-A1	N/A
VSI-A20724	38	45	52	2,00	0.079	1,20	0.047	25,39	1.000	VSC2-08045	N/A	N/A
VSI-A21024	38	45	65	2,00	0.079	1,20	0.047	25,39	1.000	VSC3-08045	N/A	N/A
VSI-A10512	30	45	60	2,20	0.087	0,60	0.024	25,39	1.000	N/A	22G45X60-A1	WA1-NWN4486
VSI-A09540	30	45	60	2,30	0.091	2,00	0.079	25,39	1.000	N/A	23K45X60-A1	WA1-NWN4348
VSI-A21626	30	45	75	2,40	0.094	1,30	0.051	25,39	1.000	VSC5-09045	23H45X75	N/A
VSI-A05028	25	45	60	2,50	0.098	1,40	0.055	25,39	1.000	N/A	25G45V60-A1	WA1-NWN1252
VSI-A10640	30	45	60	2,50	0.098	2,00	0.079	25,39	1.000	N/A	25K45X60-A1	WA1-NWN4487
VSI-A12730	2	45.5	75	1,50	0.059	1,50	0.059	25,39	1.000	N/A	N/A	WA1-NWN5185
VSI-A13024	30	46	55	1,20	0.047	1,20	0.047	25,39	1.000	N/A	12F46X55-A1	WA1-NWN4603
VSI-A12816	35	46	55	1,60	0.063	0,80	0.031	25,39	1.000	N/A	16D46F55-A1	WA1-NWN4601
VSI-A13124	30	46	52	1,90	0.075	1,20	0.047	25,39	1.000	N/A	19F46X52-A1	WA1-NWN4604
VSI-A12916	30	46	55	2,20	0.087	0,80	0.031	25,39	1.000	N/A	22D46X55-A1	WA1-NWN4602

### Small

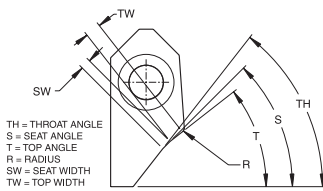

### Mini

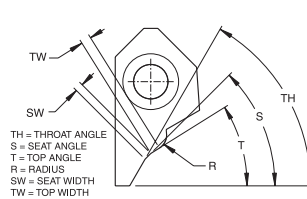

### Radius

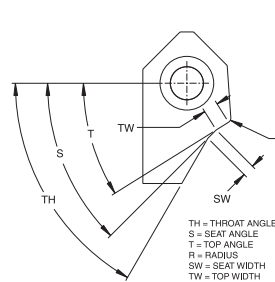

### Radius Inserts

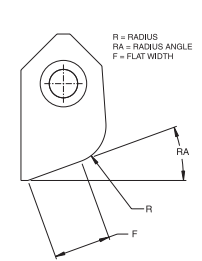



# SGM/VGS Tooling & Accessories

## Cutter Inserts – Three Angle

### Three Angle Inserts, Small

SUNNEN Part Number	Top T	Angle Seat S	Throat TH	Width				Radius R		Minimum Diameter		VSC Number	SERDI Number	NEWEN Number
				Seat SW		Top TW		mm	in.	mm	in.			
				mm	in.	mm	in.							
VSI-A23128	38	45	52	1,300	.051	1,500	.059	0,50	0,020	18,24	0,718	VSC-717	N/A	N/A
VSI-A23228	38	45	52	1,000	.039	1,500	.059	0,50	0,020	18,24	0,718	VSC-718	N/A	N/A

### Three Angle Inserts, Mini

SUNNEN Part Number	Top T	Angle Seat S	Throat TH	Width				Radius R		Minimum Diameter		VSC Number	SERDI Number	NEWEN Number
				Seat SW		Top TW		mm	in.	mm	in.			
				mm	in.	mm	in.							
VSI-A16196	32	45	60	0,80	0,031	1,00	0,039	1,50	0,059	13,51	0,532	N/A	40805-A2	WA2-NWN4496
VSI-A16796	15	45	75	1,00	0,039	1,00	0,039	1,50	0,059	13,51	0,532	N/A	41003-A2	WA2-NWN5448
VSI-A16696	20	45	60	1,00	0,039	1,00	0,039	1,50	0,059	13,51	0,532	N/A	41200-A2	WA2-NWN5442
VSI-A16596	30	45	75	1,00	0,039	1,00	0,039	1,50	0,059	13,51	0,532	N/A	41181-A2	WA2-NWN5439
VSI-A16296	32	45	60	1,00	0,039	1,00	0,039	1,50	0,059	13,51	0,532	N/A	41156-A2	WA2-NWN4497
VSI-A22796	38	45	52	1,00	0,039	1,50	0,059	1,50	0,059	13,51	0,532	VSC-718	N/A	N/A
VSI-A16396	38	45	60	1,10	0,043	1,00	0,039	1,50	0,059	13,51	0,532	N/A	41026-A2	WA2-NWN4498
VSI-A16996	32	45	60	1,20	0,047	1,00	0,039	1,50	0,059	13,51	0,532	N/A	41182-A2	N/A
VSI-A16896	30	45	60	1,30	0,051	1,00	0,039	1,50	0,059	13,51	0,532	N/A	41046-A2	WA2-NWN5449
VSI-A22696	38	45	52	1,30	0,051	1,50	0,059	1,50	0,059	13,51	0,532	VSC-717	N/A	N/A
VSI-A16496	30	45	60	1,50	0,059	1,00	0,039	1,50	0,059	13,51	0,532	N/A	41091-A2	WA2-NWN5436

### Three Angle Inserts, Radius

SUNNEN Part Number	Top T	Angle Seat S	Throat TH	Width				Radius R		Minimum Diameter		VSC Number	SERDI Number	NEWEN Number
				Seat SW		Top TW		mm	in.	mm	in.			
				mm	in.	mm	in.							
VSI-A10726	32	45	60	0,80	0,031	1,00	0,039	1,00	0,039	25,39	1,000	N/A	40805-A1	WA1-NWN4496
VSI-A11642	15	45	75	1,00	0,039	1,60	0,063	0,80	0,031	25,19	0,992	N/A	N/A	WA1-NWN5122
VSI-A12240	15	45	75	1,00	0,039	0,90	0,035	1,50	0,059	25,39	1,000	N/A	41003-A1	WA1-NWN5448
VSI-A11938	20	45	60	1,00	0,039	1,00	0,039	1,50	0,059	25,39	1,000	N/A	41200-A1	WA1-NWN5442
VSI-A11032	30	45	60	1,00	0,039	1,00	0,039	1,50	0,059	25,39	1,000	N/A	41001-A1	WA1-NWN5043
VSI-A11832	30	45	75	1,00	0,039	1,00	0,039	1,50	0,059	25,39	1,000	N/A	41181-A1	WA1-NWN5439
VSI-A12532	32	45	60	1,00	0,039	1,10	0,043	1,50	0,059	25,39	1,000	N/A	41156-A1	N/A
VSI-A10926	38	45	60	1,10	0,043	0,90	0,035	1,50	0,059	25,39	1,000	N/A	41026-A1	WA1-NWN449
VSI-A08530	32	45	60	1,20	0,047	1,50	0,059	0,50	0,020	25,39	1,000	N/A	N/A	WA1-NWN4247
VSI-A10832	32	45	60	1,20	0,047	1,10	0,043	1,50	0,059	25,39	1,000	N/A	41182-A1	WA1-NWN4497
VSI-A12332	30	45	60	1,30	0,051	1,00	0,039	1,50	0,059	25,39	1,000	N/A	41046-A1	WA1-NWN5449
VSI-A11732	30	45	60	1,50	0,059	1,00	0,039	1,50	0,059	25,39	1,000	N/A	41091-A1	WA1-NWN5436

### Radius Inserts

SUNNEN Part Number	Radius Angle S	Radius R		Flat Width F		VSC Number	SERDI Number	NEWEN Number
		mm	in.	mm	in.			
VSI-A13300	15	4,00	0,16	5,50	0,22	N/A	R4-15-A1	WA1-NWN5121
VSI-A13500	15	5,00	0,20	5,00	0,20	VSC-518	R5-15-A1	WA1-NWN5428
VSI-A13600	15	7,00	0,28	4,10	0,16	N/A	R7-15-A1	WA1-NWN5429
VSI-A13400	30	4,00	0,16	5,70	0,22	N/A	R4-30-A1	WA1-NWN5168
VSI-A13200	30	5,00	0,20	6,00	0,24	N/A	R5-30-A1	WA1-NWN5079
VSI-A13700	30	7,00	0,28	4,40	0,17	N/A	R7-30-A1	WA1-NWN5430

# SGM/VGS Cutter Inserts

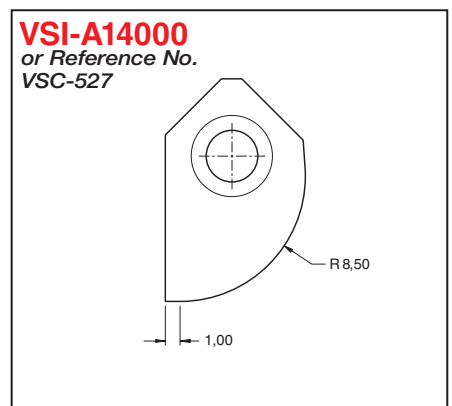
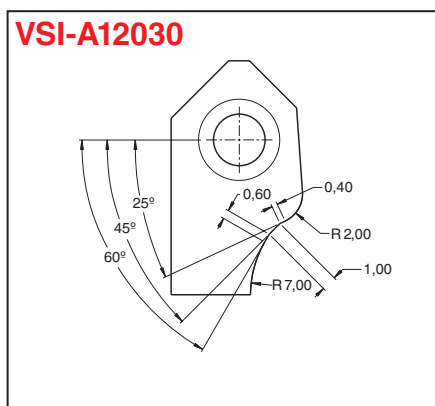
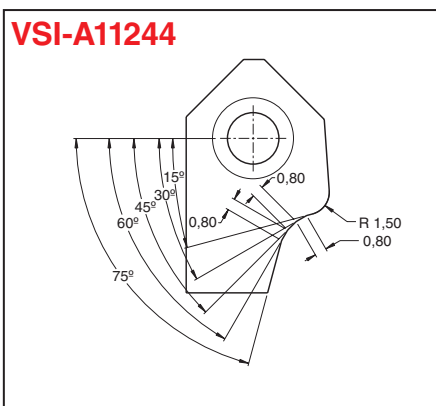
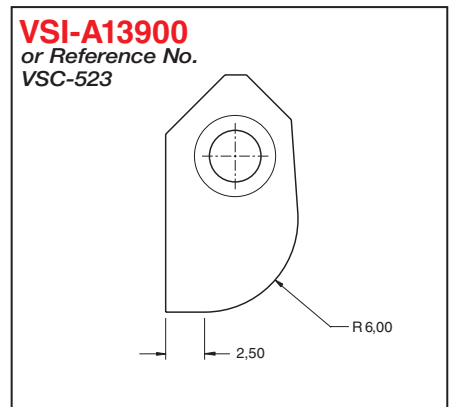
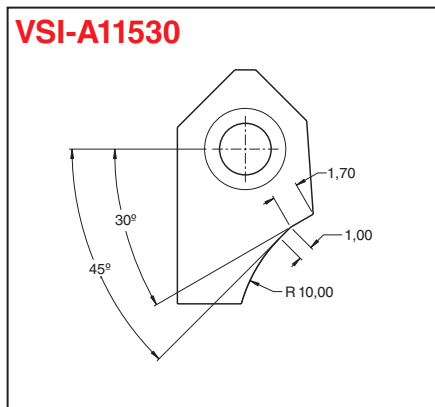
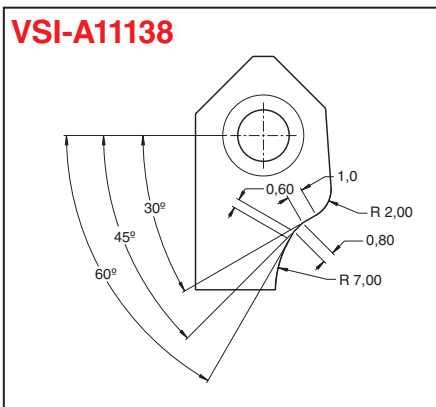
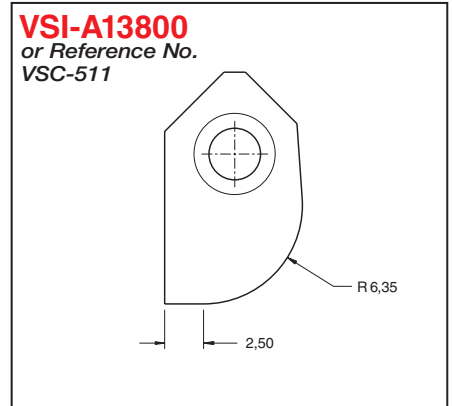
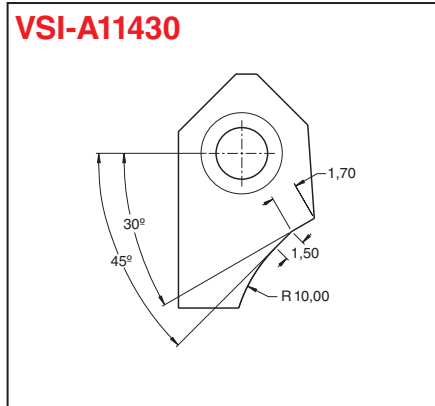
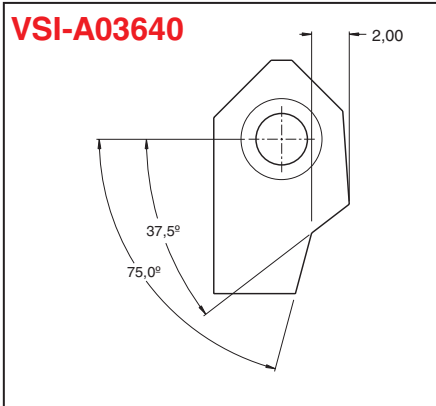
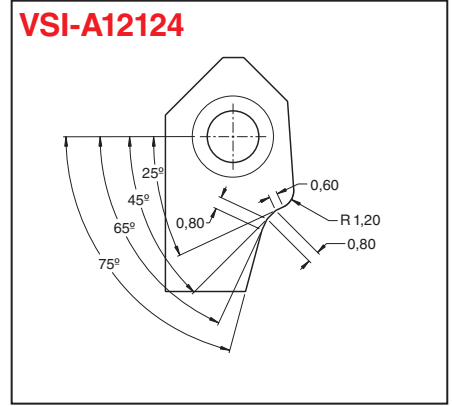
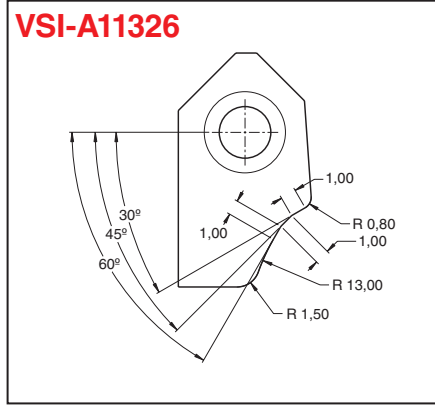
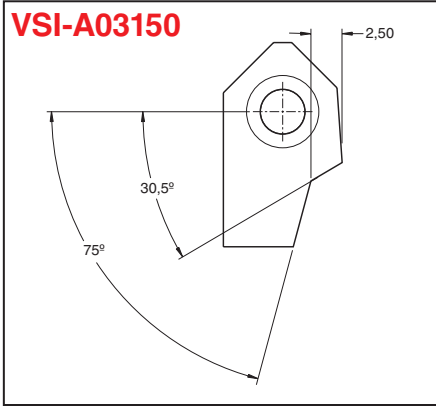

To convert from metric to inch, divide by 25.4. 1,0 mm = .039". 1,50 mm = .059". 2,0 mm = .079".

# SGM/VGS Cutter Inserts

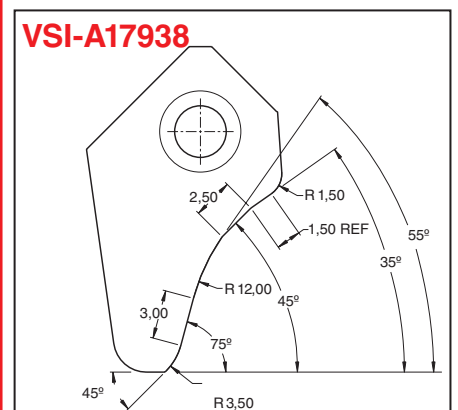
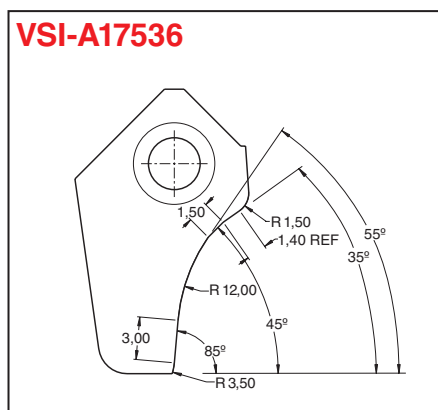
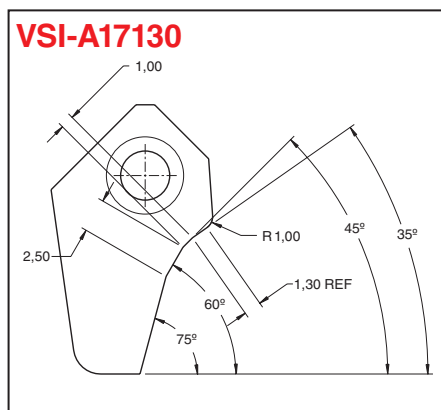
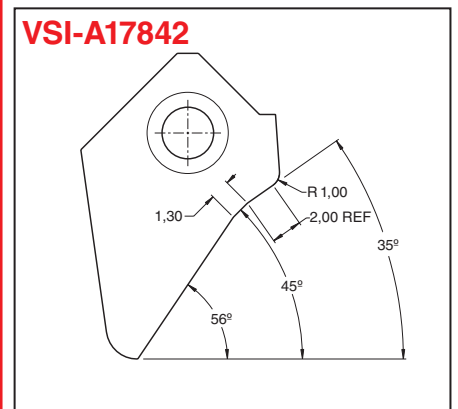
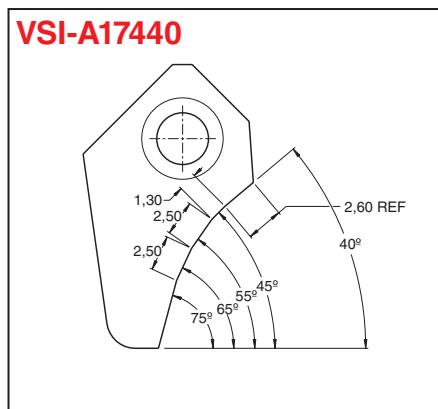
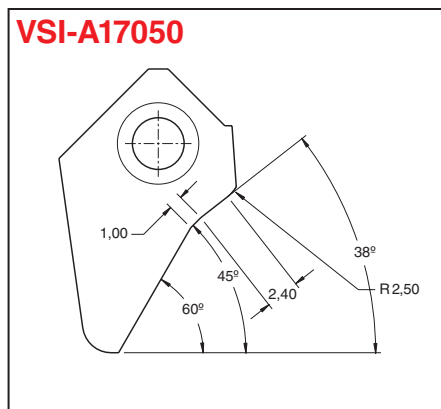
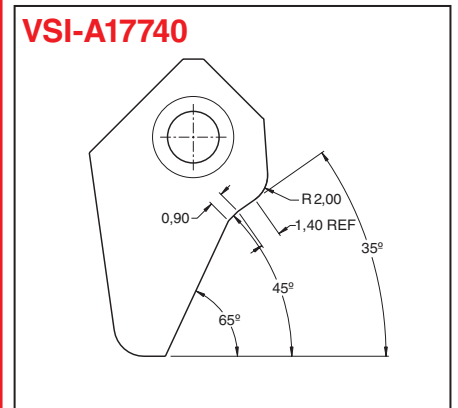
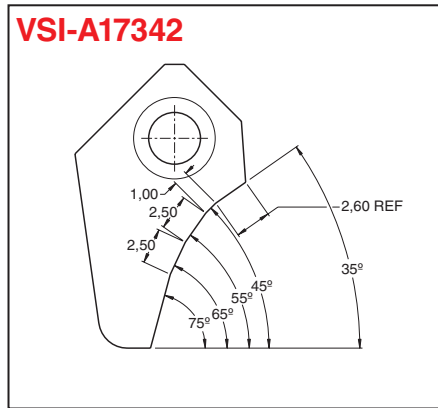
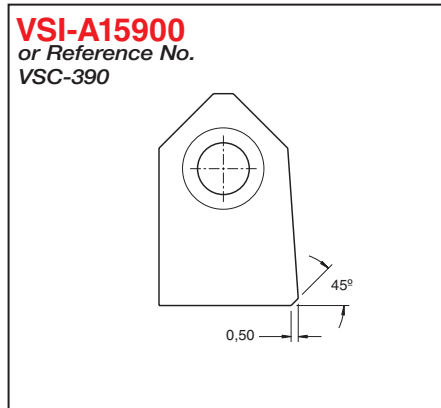
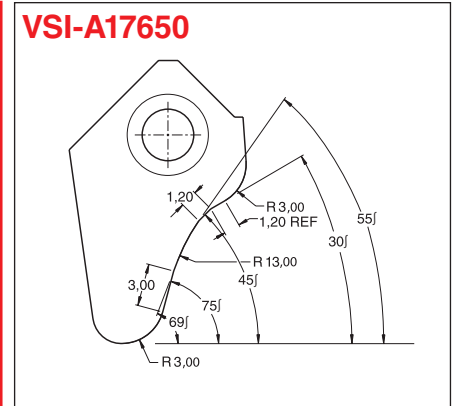
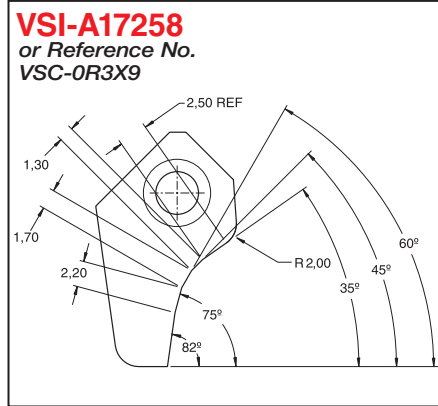
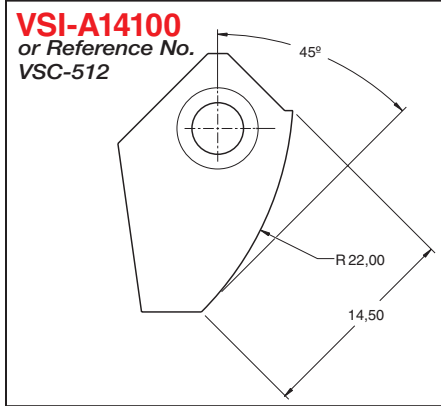

To convert from metric to inch, divide by 25.4. 1,0 mm = .039". 1,50 mm = .059". 2,0 mm = .079".



# SGM/VGS Cutter Inserts

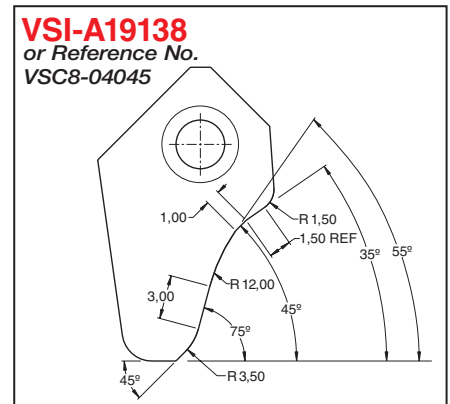
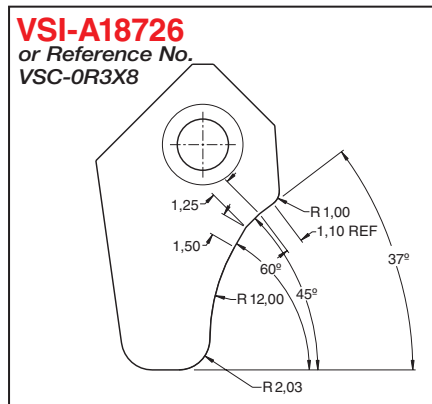
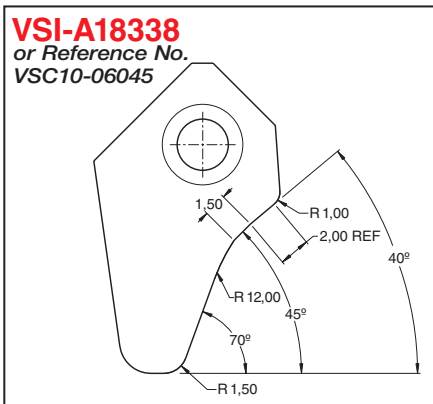
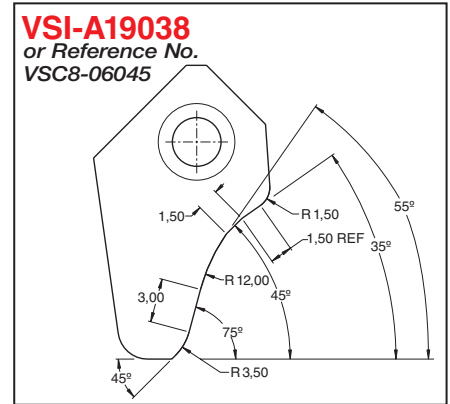
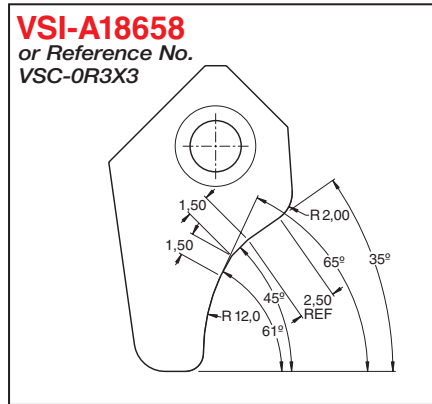
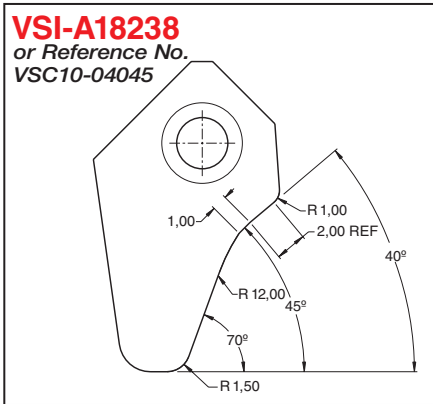
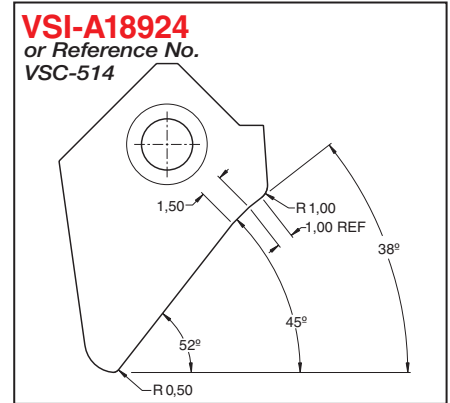
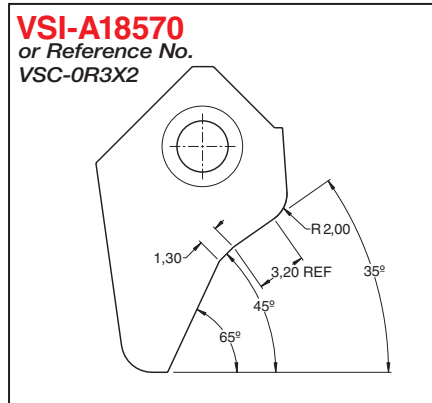
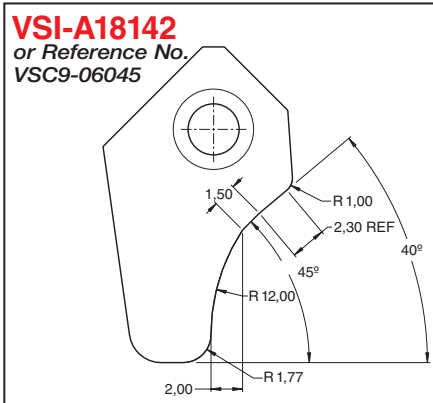
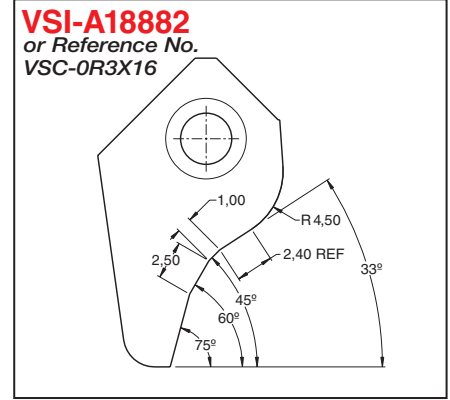
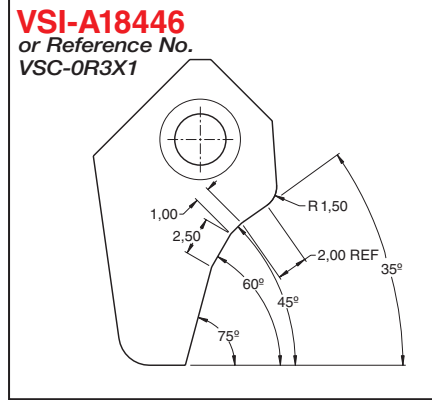
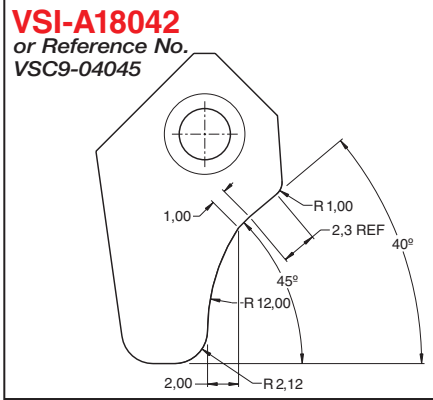

To convert from metric to inch, divide by 25.4. 1,0 mm = .039". 1,50 mm = .059". 2,0 mm = .079".

# SGM/VGS Cutter Inserts

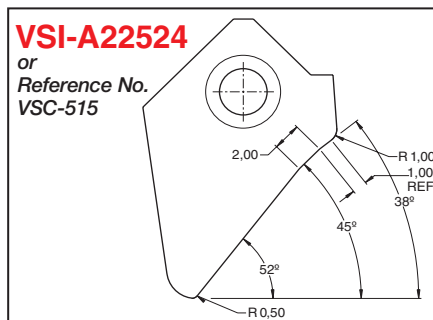
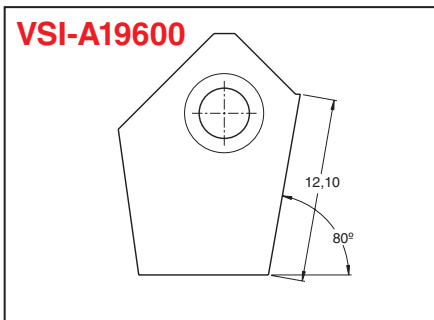
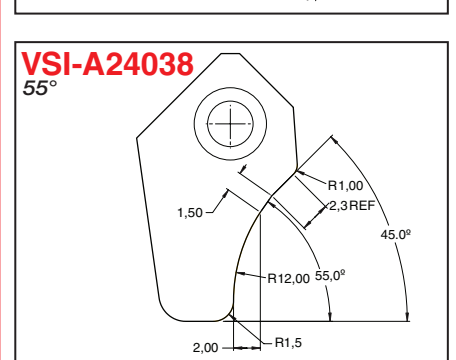
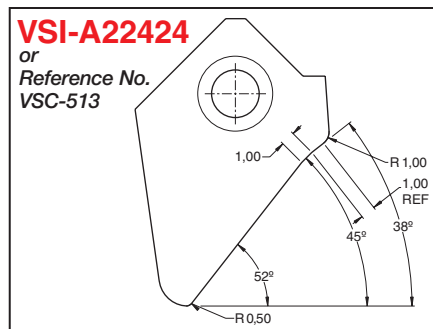
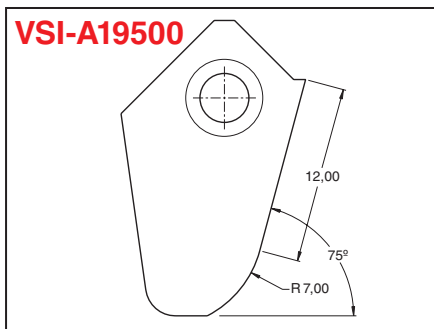
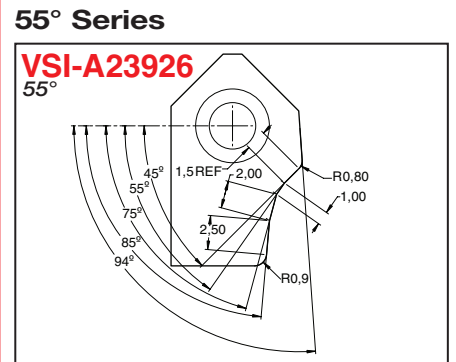
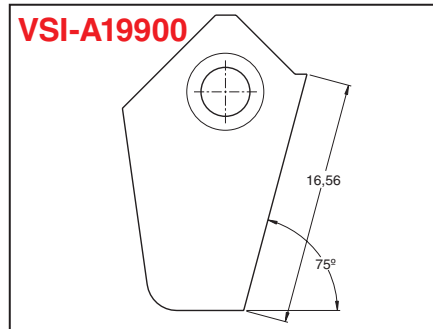
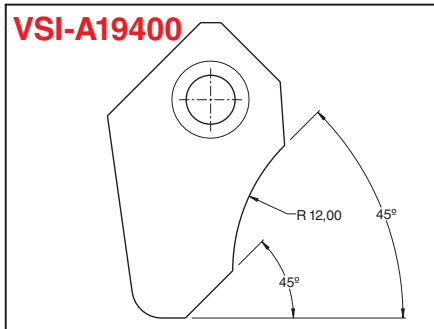
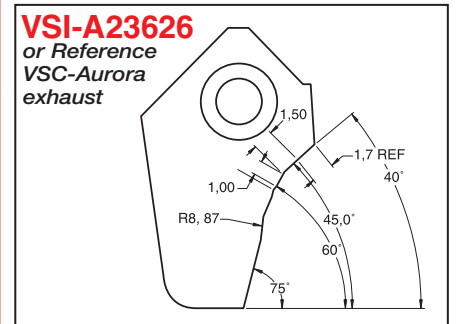
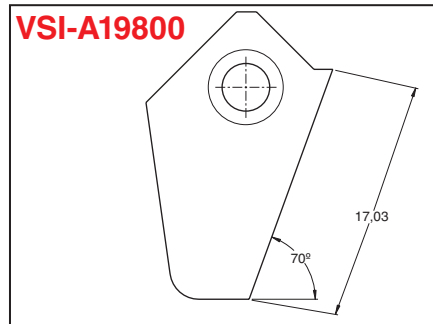
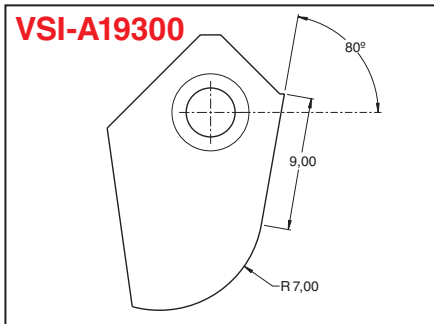
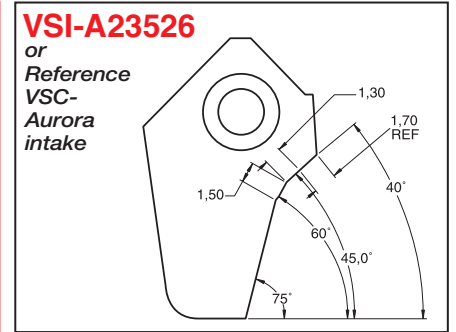
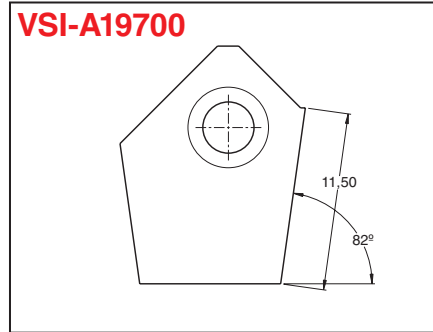
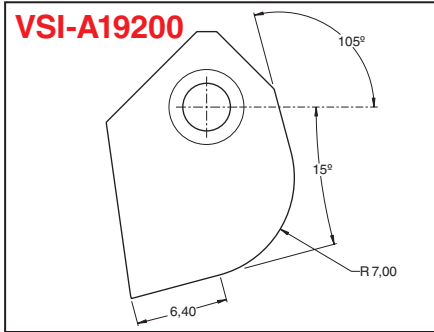

To convert from metric to inch, divide by 25.4. 1,0 mm = .039". 1,50 mm = .059". 2,0 mm = .079".

# SGM/VGS Tooling & Accessories

## Custom Carbide Inserts Order Form

Use the following blank to design a profile to meet your specific needs.

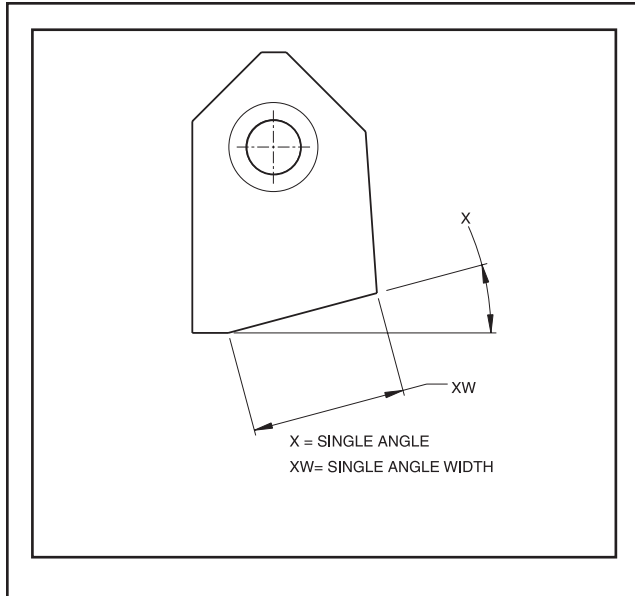

X	
XW	
TOOLING SYSTEM: <input type="checkbox"/> Sunnen <input type="checkbox"/> Newen <input type="checkbox"/> Serdi	
MINIMUM DIA. REQUIRED _____	
QUANTITY _____	
MAKE OF HEAD _____	

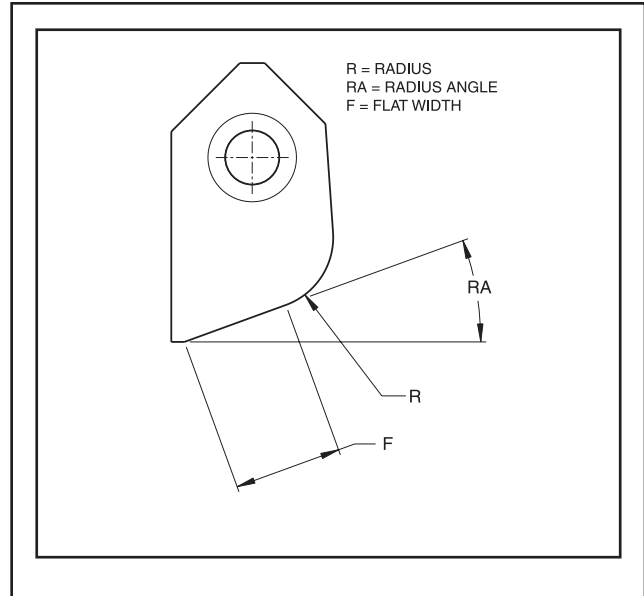

R	
RA	
F	
TOOLING SYSTEM: <input type="checkbox"/> Sunnen <input type="checkbox"/> Newen <input type="checkbox"/> Serdi	
MINIMUM DIA. REQUIRED _____	
QUANTITY _____	
MAKE OF HEAD _____	

### COMPANY INFORMATION

COMPANY NAME \_\_\_\_\_  
 ADDRESS \_\_\_\_\_  
 \_\_\_\_\_  
 ACCOUNT NO. \_\_\_\_\_ P.O. NO. \_\_\_\_\_  
 CONTACT NAME \_\_\_\_\_  
 TITLE \_\_\_\_\_  
 TELEPHONE \_\_\_\_\_  
 FAX \_\_\_\_\_  
 SIGNATURE \_\_\_\_\_

SHIPPING  
 SHIPPED: 2 DAYS  
 AFTER FINAL SIGNED  
 APPROVAL OF YOUR  
 PROFILE DRAWING.  
 GROUND  
 3 DAY  
 2ND DAY  
 NEXT DAY

DATE \_\_\_\_\_

**SUNNEN PRODUCTS COMPANY**  
 7910 Manchester Road • St. Louis, MO 63143 U.S.A. • Ph: 314-781-2100 • Fax: 314-951-2751  
 www.sunnen.com  
 U.S.A. Toll-Free Sales and Service – Auto: 1-800-325-3670  
 International Division Fax: 314-781-0692



# SGM/VGS Tooling & Accessories

## Custom Carbide Inserts Order Form

Use the following blank to design a profile to meet your specific needs.

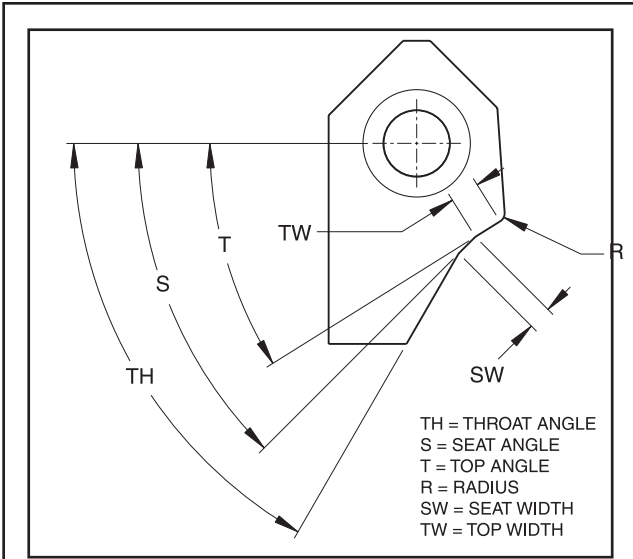

TH	
S	
T	
R	
SW	
TW	

TOOLING SYSTEM: Sunnen Newen Serdi

MINIMUM DIA. REQUIRED \_\_\_\_\_

QUANTITY \_\_\_\_\_

MAKE OF HEAD \_\_\_\_\_

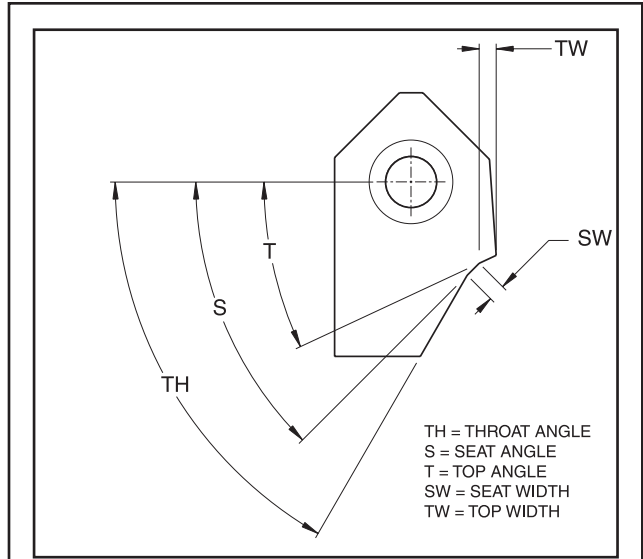

TH	
S	
T	
R	
SW	
TW	

TOOLING SYSTEM: Sunnen Newen Serdi

MINIMUM DIA. REQUIRED \_\_\_\_\_

QUANTITY \_\_\_\_\_

MAKE OF HEAD \_\_\_\_\_

### COMPANY INFORMATION

COMPANY NAME \_\_\_\_\_  
ADDRESS \_\_\_\_\_

ACCOUNT NO. \_\_\_\_\_ P.O. NO. \_\_\_\_\_

CONTACT NAME \_\_\_\_\_

TITLE \_\_\_\_\_

TELEPHONE \_\_\_\_\_

FAX \_\_\_\_\_

SIGNATURE \_\_\_\_\_

SHIPPING  
SHIPPED: 2 DAYS  
AFTER FINAL SIGNED  
APPROVAL OF YOUR  
PROFILE DRAWING.

- GROUND  
 3 DAY  
 2ND DAY  
 NEXT DAY

DATE \_\_\_\_\_

### SUNNEN PRODUCTS COMPANY

7910 Manchester Road • St. Louis, MO 63143 U.S.A. • Ph: 314-781-2100 • Fax: 314-951-2751

www.sunnen.com

U.S.A. Toll-Free Sales and Service – Auto: 1-800-325-3670

International Division Fax: 314-781-0692





# SGM/VGS Tooling & Accessories

## Custom Carbide Inserts Order Form

Use the following blank to design a profile to meet your specific needs.

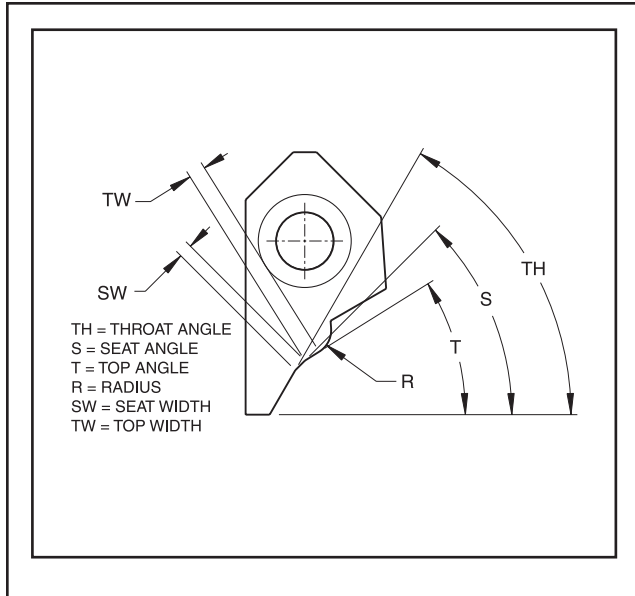

TH	
S	
T	
R	
SW	
TW	
TOOLING SYSTEM: <input type="checkbox"/> Sunnen <input type="checkbox"/> Newen <input type="checkbox"/> Serdi	
MINIMUM DIA. REQUIRED _____	
QUANTITY _____	
MAKE OF HEAD _____	

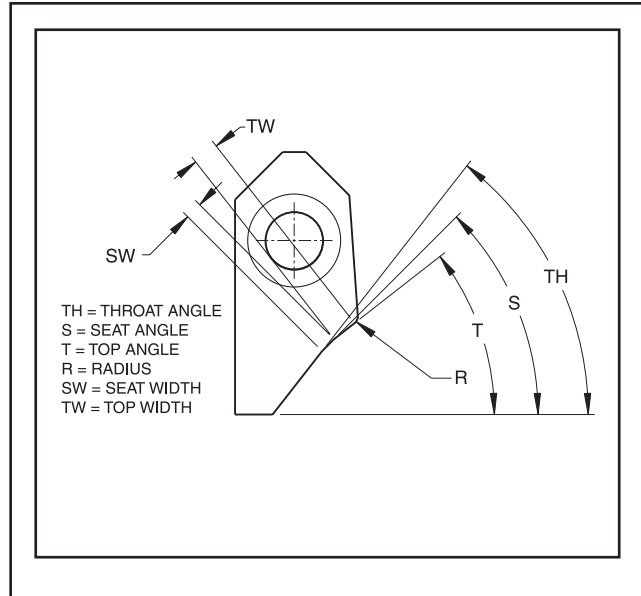

TH	
S	
T	
R	
SW	
TW	
TOOLING SYSTEM: <input type="checkbox"/> Sunnen <input type="checkbox"/> Newen <input type="checkbox"/> Serdi	
MINIMUM DIA. REQUIRED _____	
QUANTITY _____	
MAKE OF HEAD _____	

### COMPANY INFORMATION

COMPANY NAME \_\_\_\_\_  
 ADDRESS \_\_\_\_\_  
 \_\_\_\_\_  
 ACCOUNT NO. \_\_\_\_\_ P.O. NO. \_\_\_\_\_  
 CONTACT NAME \_\_\_\_\_  
 TITLE \_\_\_\_\_  
 TELEPHONE \_\_\_\_\_  
 FAX \_\_\_\_\_  
 SIGNATURE \_\_\_\_\_

SHIPPING  
 SHIPPED: 2 DAYS  
 AFTER FINAL SIGNED  
 APPROVAL OF YOUR  
 PROFILE DRAWING.  
 GROUND  
 3 DAY  
 2ND DAY  
 NEXT DAY

DATE \_\_\_\_\_

**SUNNEN PRODUCTS COMPANY**  
 7910 Manchester Road • St. Louis, MO 63143 U.S.A. • Ph: 314-781-2100 • Fax: 314-951-2751  
 www.sunnen.com  
 U.S.A. Toll-Free Sales and Service – Auto: 1-800-325-3670  
 International Division Fax: 314-781-0692



# SGM/VGS Tooling & Accessories

## Custom Carbide Inserts Order Form

Use the following blank to design a profile to meet your specific needs.

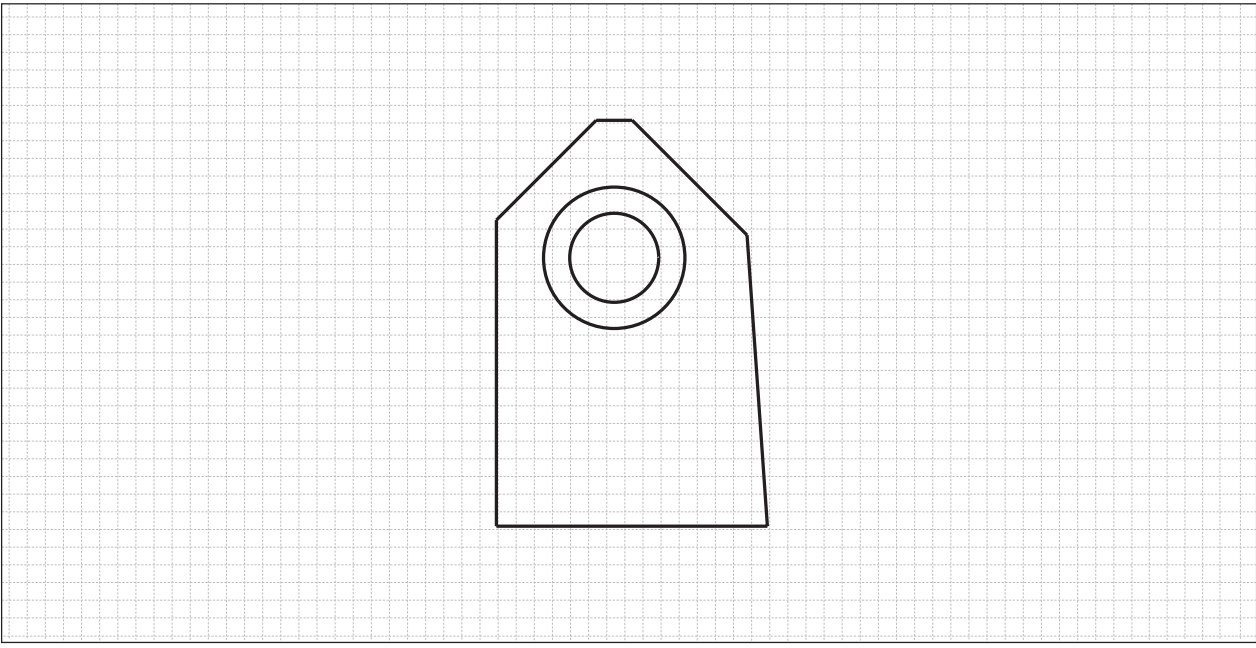
			
_____	_____	_____	_____
_____	_____	_____	_____
_____	_____	_____	_____
TOOLING SYSTEM: <input type="checkbox"/> Sunnen <input type="checkbox"/> Newen <input type="checkbox"/> Serdi			
MINIMUM DIA. REQUIRED _____			
QUANTITY _____			
MAKE OF HEAD _____			

### COMPANY INFORMATION

COMPANY NAME \_\_\_\_\_  
ADDRESS \_\_\_\_\_  
\_\_\_\_\_

ACCOUNT NO. \_\_\_\_\_ P.O. NO. \_\_\_\_\_  
CONTACT NAME \_\_\_\_\_  
TITLE \_\_\_\_\_  
TELEPHONE \_\_\_\_\_  
FAX \_\_\_\_\_

SIGNATURE \_\_\_\_\_

SHIPPING  
SHIPPED: 2 DAYS  
AFTER FINAL SIGNED  
APPROVAL OF YOUR  
PROFILE DRAWING.

- GROUND
- 3 DAY
- 2ND DAY
- NEXT DAY

DATE \_\_\_\_\_

#### SUNNEN PRODUCTS COMPANY

7910 Manchester Road • St. Louis, MO 63143 U.S.A. • Ph: 314-781-2100 • Fax: 314-951-2751

www.sunnen.com

U.S.A. Toll-Free Sales and Service – Auto: 1-800-325-3670

International Division Fax: 314-781-0692



# SGM/VGS Tooling & Accessories

## Custom Carbide Inserts Order Form

Use the following blank to design a profile to meet your specific needs.

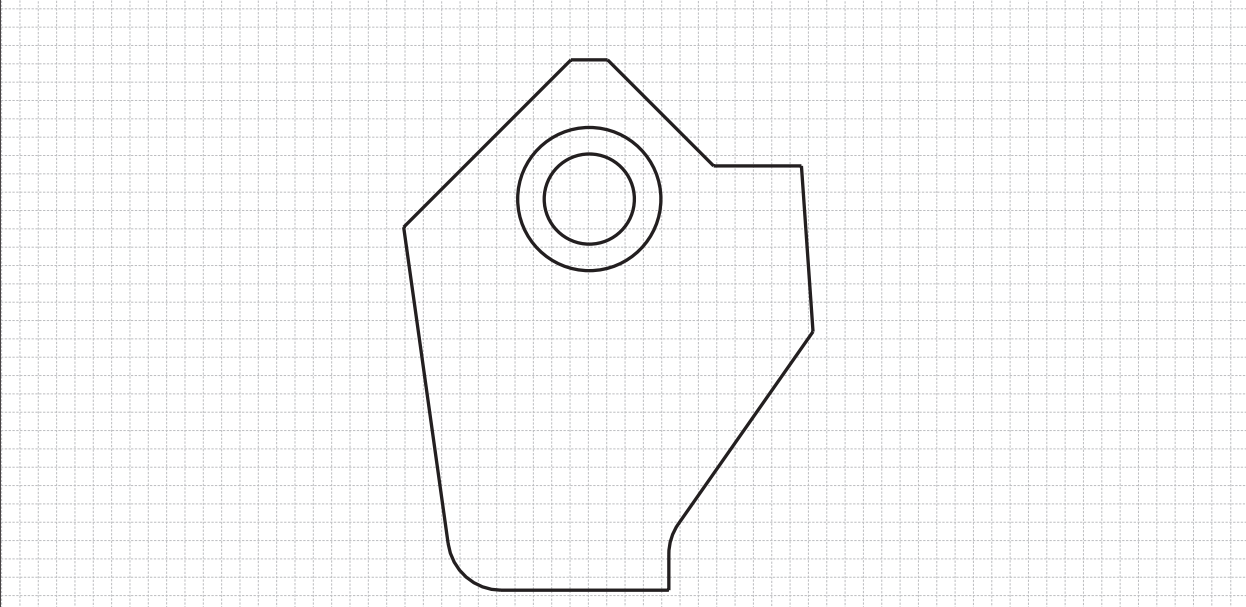

**TOOLING SYSTEM:** Sunnen Newen Serdi

**MINIMUM DIA. REQUIRED** \_\_\_\_\_

**QUANTITY** \_\_\_\_\_

**MAKE OF HEAD** \_\_\_\_\_

### COMPANY INFORMATION

COMPANY NAME \_\_\_\_\_

ADDRESS \_\_\_\_\_

\_\_\_\_\_

ACCOUNT NO. \_\_\_\_\_ P.O. NO. \_\_\_\_\_

CONTACT NAME \_\_\_\_\_

TITLE \_\_\_\_\_

TELEPHONE \_\_\_\_\_

FAX \_\_\_\_\_

SIGNATURE \_\_\_\_\_

**SHIPPING**

SHIPPED: 2 DAYS  
AFTER FINAL SIGNED  
APPROVAL OF YOUR  
PROFILE DRAWING.

GROUND  
 3 DAY  
 2ND DAY  
 NEXT DAY

DATE \_\_\_\_\_

**SUNNEN PRODUCTS COMPANY**  
7910 Manchester Road • St. Louis, MO 63143 U.S.A. • Ph: 314-781-2100 • Fax: 314-951-2751  
www.sunnen.com  
U.S.A. Toll-Free Sales and Service – Auto: 1-800-325-3670  
International Division Fax: 314-781-0692



# SGM/VGS Tooling & Accessories

## Custom Carbide Cutters Order Form For VSC Style Cutters

Use the following blank to design a profile to meet your specific needs.

**MINIMUM DIA. REQUIRED** \_\_\_\_\_

**QUANTITY** \_\_\_\_\_

**MAKE OF HEAD** \_\_\_\_\_

### COMPANY INFORMATION

COMPANY NAME \_\_\_\_\_  
 ADDRESS \_\_\_\_\_  
 \_\_\_\_\_  
 \_\_\_\_\_

ACCOUNT NO. \_\_\_\_\_ P.O. NO. \_\_\_\_\_

CONTACT NAME \_\_\_\_\_  
 TITLE \_\_\_\_\_  
 TELEPHONE \_\_\_\_\_  
 FAX \_\_\_\_\_

SIGNATURE \_\_\_\_\_

**SHIPPING**

SHIPPED: 2 DAYS  
 AFTER FINAL SIGNED  
 APPROVAL OF YOUR  
 PROFILE DRAWING.

GROUND

3 DAY

2ND DAY

NEXT DAY

DATE \_\_\_\_\_

**SUNNEN PRODUCTS COMPANY**  
 7910 Manchester Road • St. Louis, MO 63143 U.S.A. • Ph: 314-781-2100 • Fax: 314-951-2751  
 www.sunnen.com  
 U.S.A. Toll-Free Sales and Service – Auto: 1-800-325-3670  
 International Division Fax: 314-781-0692





# SGM/VGS Tooling & Accessories

## Custom Carbide Cutters Order Form For VSC Style Cutters

Use the following blank to design a profile to meet your specific needs.

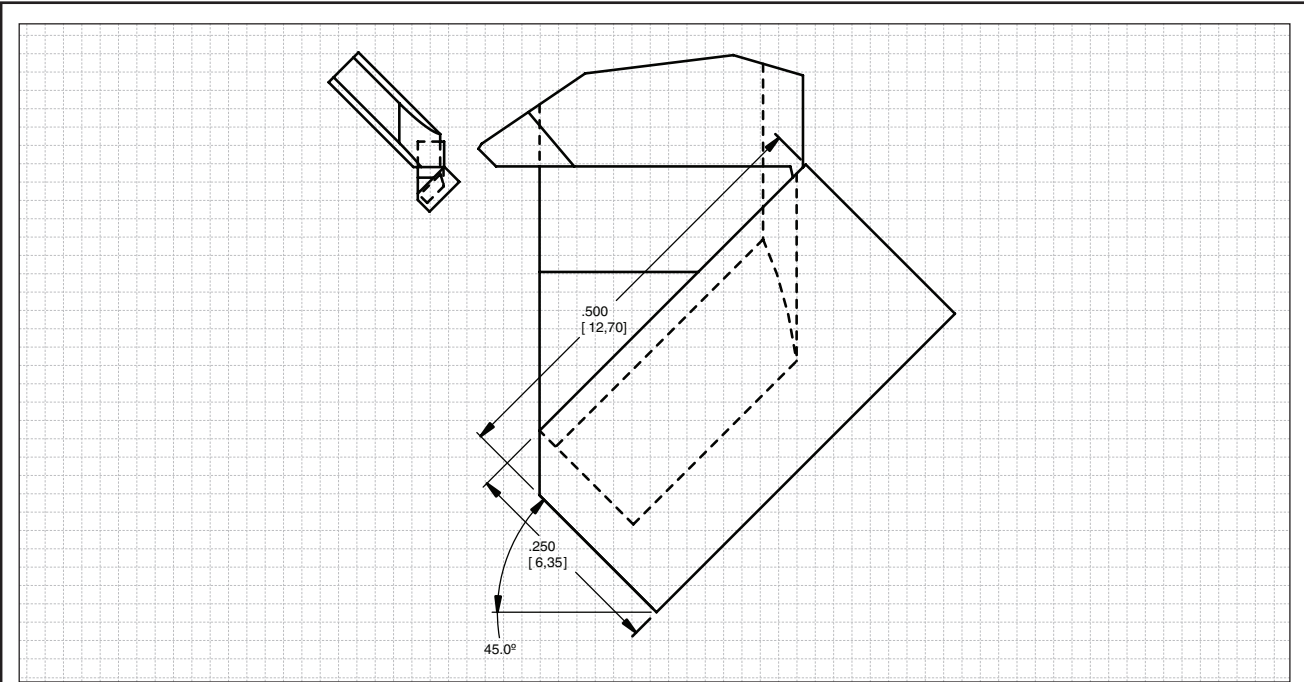

_____	_____
_____	_____
_____	_____
_____	_____

TOOLING SYSTEM: Sunnen Newen Serdi

MINIMUM DIA. REQUIRED \_\_\_\_\_

QUANTITY \_\_\_\_\_

MAKE OF HEAD \_\_\_\_\_

### COMPANY INFORMATION

COMPANY NAME \_\_\_\_\_

ADDRESS \_\_\_\_\_

ACCOUNT NO. \_\_\_\_\_ P.O. NO. \_\_\_\_\_

CONTACT NAME \_\_\_\_\_

TITLE \_\_\_\_\_

TELEPHONE \_\_\_\_\_

FAX \_\_\_\_\_

SIGNATURE \_\_\_\_\_

SHIPPING  
SHIPPED: 2 DAYS  
AFTER FINAL SIGNED  
APPROVAL OF YOUR  
PROFILE DRAWING.

- GROUND
- 3 DAY
- 2ND DAY
- NEXT DAY

DATE \_\_\_\_\_

**SUNNEN PRODUCTS COMPANY**  
7910 Manchester Road • St. Louis, MO 63143 U.S.A. • Ph: 314-781-2100 • Fax: 314-951-2751  
www.sunnen.com

U.S.A. Toll-Free Sales and Service – Auto: 1-800-325-3670  
International Division Fax: 314-781-0692



# SGM/VGS Tooling & Accessories

## VSC Single-Blade 3-Angle Fixed Seat Cutter

### VSC-700 Single-Blade, 3-Angle Seat Cutter Kit



Cuts all three angles simultaneously and eliminates grinding. For engines with small diameter valves such as multi-valve automotive heads or small engines with valve sizes from .75" to 1.0" (19 to 25 mm). Used with Sunnen VGS-19 and VGS-20 and SGM 1500 Valve Seat & Guide Machines and Sunnen SVP pilots listed separately.

Kit Includes:

Part No.	Descriptions
PSP-212A	Spring, Short
VSC-710	Cutter Body Assembly .67-1.0 in. (17-25 mm)
PSP-213A	Spring, Long
SGM-1200	Pilot Removal Tool
VSC-709A	Spring Bushing (4)
VSC-717	Cutter, 38-45-52 Seat Angle .051
VSC-718	Cutter, 38-45-52 Seat Angle .040
VSC-780	Level Bushing

Note: VGS and VSC tooling adapters are available for competitive machines. See page 29. See pages 31 & 32 for pilots for use with VSC-500 and VSC-700. pages

### VSC-500 Single-Blade, 3-Angle Seat Cutter Kit



Features three angle, single blade carbide cutters.

The Sunnen VSC Seat Angle Cutter Kit is designed for use with Sunnen Valve Guide & Seat Machines, Models VGS-19, VGS-20, and SGM 1500.

Kit Includes:

Part No.	Descriptions
VSC-205	Cutter Body 1.0"-1.6" (25-41 mm)
VSC-305	Cutter Body 1.5"-2.0" (38-52 mm)
VSC-350	Cutter Body 1.9"-2.5" (47-64 mm)
VSC-400	Setting Fixture
VSC-50	Tool Sharpening Fixture
PSP-215A	Spring, Short
PSP-216A	Spring, Long
VSC-509A	Spring Bushing
PWMM-5A	Hex T-Wrench
VSC-08045	Cutter, 30-45-60
VSC-06045	Cutter, 30-45-60

### VSC-500S Single-Blade, 3-Angle Seat Cutter Kit (Sioux Pilots)

Same as VSC-500 except Cutter Bodies fit Sioux .385" (9,8 mm) pilots.

### VSC-505 Single-Blade, 3-Angle Seat Cutting Kit

for Harley® Cylinder Heads



Valve seat machining kit designed for Harley cylinder heads features three angle, single blade carbide cutters. Eliminates grinding and cuts all three finished seat angles simultaneously while maintaining exact seat width and angles from seat to seat. Drastically reduces the time required for machining valve seats and increases accuracy.

For use with Sunnen .389 inch (9,9 mm) precision valve guide pilots and Sunnen Valve Guide and Seat Machines, models VGS-19, VGS-20, and SGM 1500.

Kit Includes:

Part No.	Descriptions
VSC-205	Cutter Body 1.0 - 1.6 inch (25-41 mm)
VSC-305	Cutter Body 1.5 - 2.0 inch (38-52 mm)
VSC-400	Setting Fixture
VSC-50	Tool Sharpening Fixture
PSP-215A	Spring, Short
PSP-216A	Spring, Long
VSC-509A	Spring Bushings (4)
PWMM-5A	Hex T-Wrench
VSC-06045	(2) Cutter 30-45-60

### VSC-505S Single-Blade, 3-Angle Seat Cutter Kit (Sioux Pilots)

Same as VSC-505 except cutter bodies fit Sioux .385 inch (9,8 mm) pilots.

### Replacement Items for VSC Cutter Bodies

Part No.	Descriptions	Applications
ASPC-947A	Screw	VSC-200 and VSC-205 All VSC-300 and VSC-305 Variations VSC-350
VSC-202A	Wedge#2	VSC-710 All VSC-200 and VSC-205 Variations
VSC-302A	Wedge#3	VSC-300 and VSC-305 All VSC-350 Variations

# SGM/VGS Tooling & Accessories

## VSC Standard Valve Seat Cutters

Part No.	Angles Degrees		Seat Width (mm) in.	Engines	Profile No.	Part No.	Angles Degrees		Seat Width (mm) in.	Engines	Profile No.
	Top-Seat-Throat						Top-Seat-Throat				
VSC-15	15 only				13	VSC3-04045	38-45-65		1,0 .040	High Performance	5
VSC-20	20 only			John Deere	14	VSC3-06045	38-45-65		1,5 .060	USA High Performance	5
VSC-30	30 only				15	VSC3-08045	38-45-65		2,0 .080	Alfa Romeo, Fiat, Ford Europe, Jaguar, Mercedes, Peugeot, Plymouth, Porsche, Renault, Rover, Saab, Volvo	5
VSC-45	45 only				17						
VSC-60	60 only				18						
VSC-75	75 only				19						
VSC-375	37.5 only			6.9 International Harvester	16	VSC4-04045	15-45-60		1,0 .040	High Performance	6
VSC-390	Flat Bottom			Flush Cutting Insert Seats	20	VSC4-06045	15-45-60		1,5 .060	Chrysler, Dodge, Plymouth	6
VSC-511	Chamfer Relief			.25 in. (6,35 mm) Radius	21	VSC4-08045	15-45-60		2,0 .080	Chrysler, Dodge	6
VSC-512	Chamfer Relief			.875 in. (22,22 mm) Radius	22	VSC5-04045	30-45-75		1,0 .040	High Performance	7
VSC-518	Chamfer Relief			.188 in. (4,77 mm) Radius	32	VSC5-06045	30-45-75		1,5 .060	Pontiac, Nissan	7
VSC-523	Chamfer Relief			.236 in. (5,99 mm) Radius	33	VSC5-08045	30-45-75		2,0 .080	Volkswagen	7
VSC-527	Chamfer Relief			.344 in. (8,73 mm) Radius	34	VSC5-09045	30-45-75		2,4 .090	Volkswagen	7
VSC-575	Chamfer Relief			75 degree bowl cutter assembly	35	VSC6-04045	20-45-75		1,0 .040	Pontiac	8
VSC-532	25-37.5-75		1,5 .060	6.9 International Harvester	31	VSC6-06045	20-45-75		1,5 .060	Pontiac	8
VSC-04030	15-30-60		1,0 .040	High Performance	1	VSC6-08045	20-45-75		2,0 .080	Pontiac	8
VSC-06030	15-30-60		1,5 .060	High Performance	1	VSC7-04030	23-30-52		1,0 .040	High Performance, Pont.	9
VSC-08030	15-30-60		2,0 .080	High Performance	1	VSC7-06030	23-30-52		1,5 .060	Ford, GMC, Plym., Pont., Renault	9
VSC-04045	30-45-60		1,0 .040	USA High Performance	2	VSC7-08030	23-30-52		2,0 .080	AMC, Chevrolet, Ford, Plym., Pont.	9
VSC-06045	30-45-60		1,5 .060	AMC, Austin, BMW, Chevrolet, Ford, Mercedes, Mitsubishi, Nissan, Volvo	2						
VSC-08045	30-45-60		2,0 .080	High Performance	2	VSC8-04045	35-45-75		1,0 .040	Motorcycle & High Performance (#4043B)	10
VSC1-04045	25-45-60		1,0 .040	Chevrolet, Ford, Ford Diesel, GMC, Mercedes	3	VSC8-06045	35-45-75 12 mm Radius		1,5 .060	Motorcycle & High Performance (Large Carbide, 12 mmR)	10
VSC1-06045	25-45-60		1,5 .060	High Performance	3	VSC9-04045	40-45 12 mm Radius		1,0 .040	Motorcycle & High Performance (#4047B)	11
VSC1-08045	25-45-60		2,0 .080	High Performance	3	VSC9-06045	40-45 12 mm Radius		1,5 .060	Motorcycle & High Performance (Large Carbide, 12 mmR)	11
VSC2-04045	38-45-52		1,0 .040	USA High Performance	4	VSC10-04045	40-45-70 12 mm Radius		1,0 .040	Motorcycle & High Performance (#4048B)	12
VSC2-06045	38-45-52		1,5 .060	High Performance	4	VSC10-06045	40-45-70 12 mm Radius		1,5 .060	Motorcycle & High Performance	12
VSC2-08045	38-45-52		2,0 .080	High Performance	4						
VSC-513	38-45-52		1,0 .040	USA High Performance	23						
	Longer throat length										
VSC-514	38-45-52		1,5 .060	USA High Performance	24						
	Longer throat length										
VSC-515	38-45-52		2,0 .080	USA High Performance	25						
	Longer throat length										

NOTE: Cutters shown are offered as a suggested starting point. Select cutters according to manufacturer recommendations. Use pages 18-24 for ordering.

### VSC Form Tools



#### VSC-511

used for chamfer relief, cuts with a .25" (6,35 mm) radius.



#### VSC-512

used for throat alterations, cuts with a .875" (22,22 mm) radius.



#### VSC-518

used for chamfer relief, cuts with a .188" (4,77 mm) radius.



#### VSC-523

used for chamfer relief, cuts with a .236" (5,99 mm) radius.



#### VSC-527

used for chamfer relief, cuts with a .344" (8,73 mm) radius.



#### VSC-575

75 degree bowl cutter assembly.



### VSC-K68B Cutter Blank

The VSC-K68B is a blank cutter for the VSC system. This cutter consists of an unground carbide tip silver-soldered on a cutter blank. The blank cutter can then be ground by the user to any desired angles or specifications. Great for high performance shops that use non-standard valve seat configurations.



### VSC-RB Radius Cutter Blank

Similar to the VSC-K68B but supplied with a .5" (12,7 mm) wide carbide tip. This allows the user to grind a radius suitable to individual requirements.

### Special Profile VSC Cutters

Special profile VSC cutters are available on a special order basis. These special profile cutters will be made from a blank cutter ground to your specifications. When ordering, send full description with all specifications.

# SGM/VGS Tooling & Accessories

## VSC Cutter Profiles – Sunnen Standard Valve Seat Cutters

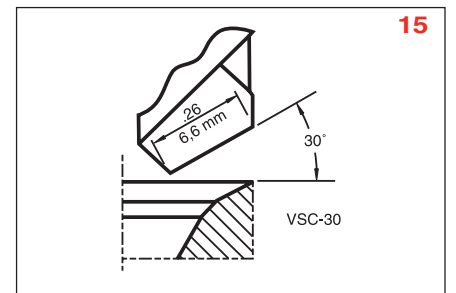
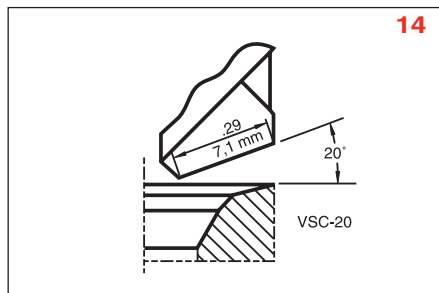
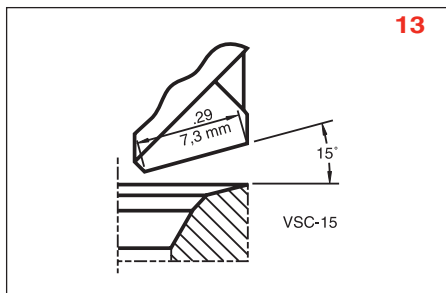
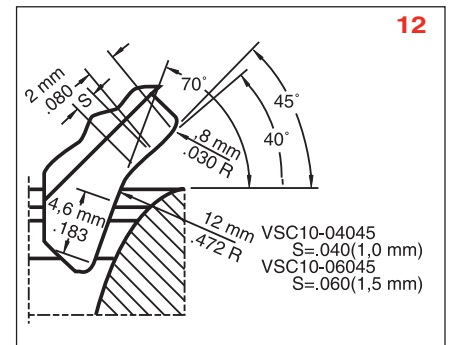
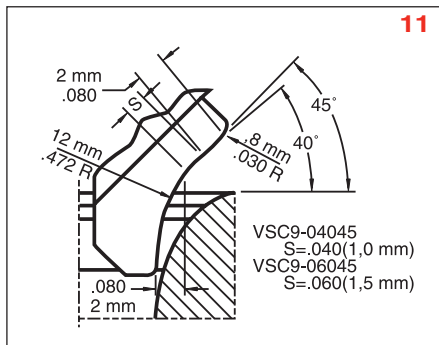
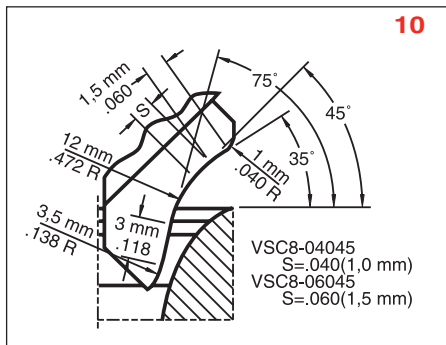
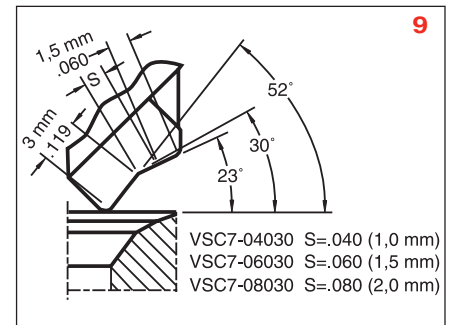
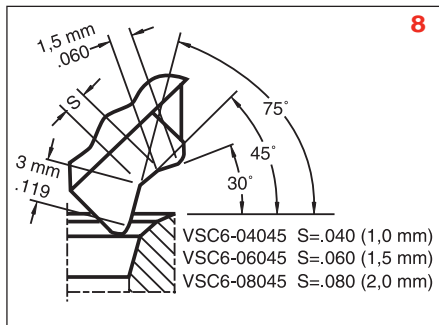
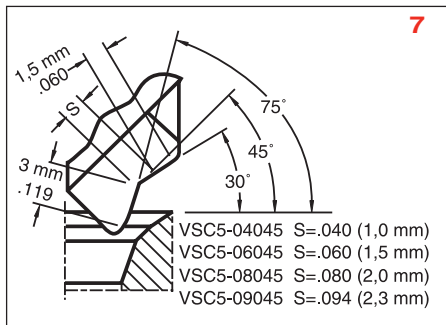
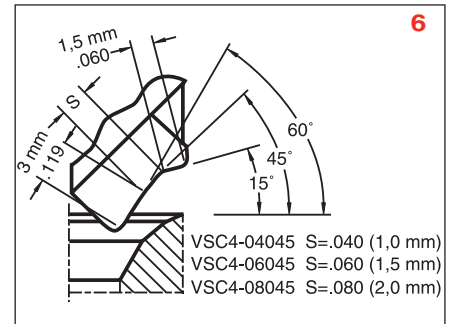
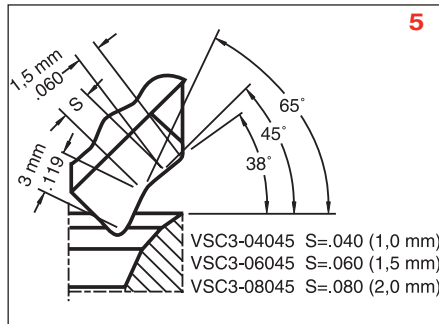
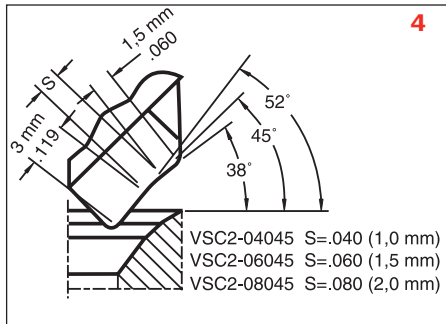
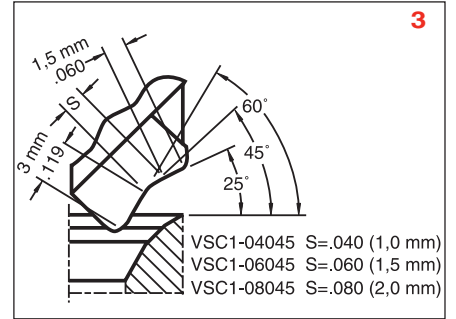
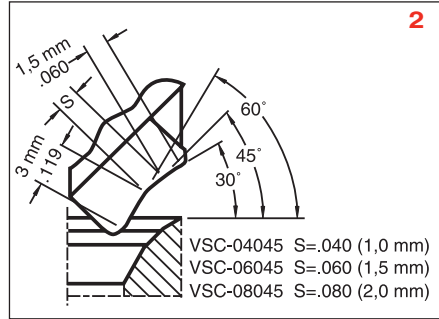
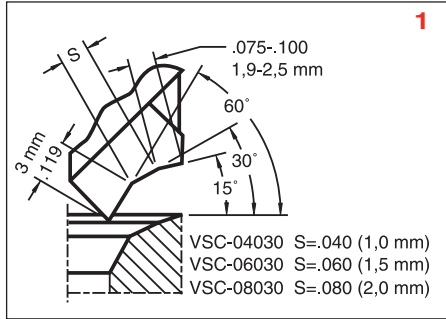



# SGM/VGS Tooling & Accessories

## VSC Cutter Profiles – Sunnen Standard Valve Seat Cutters

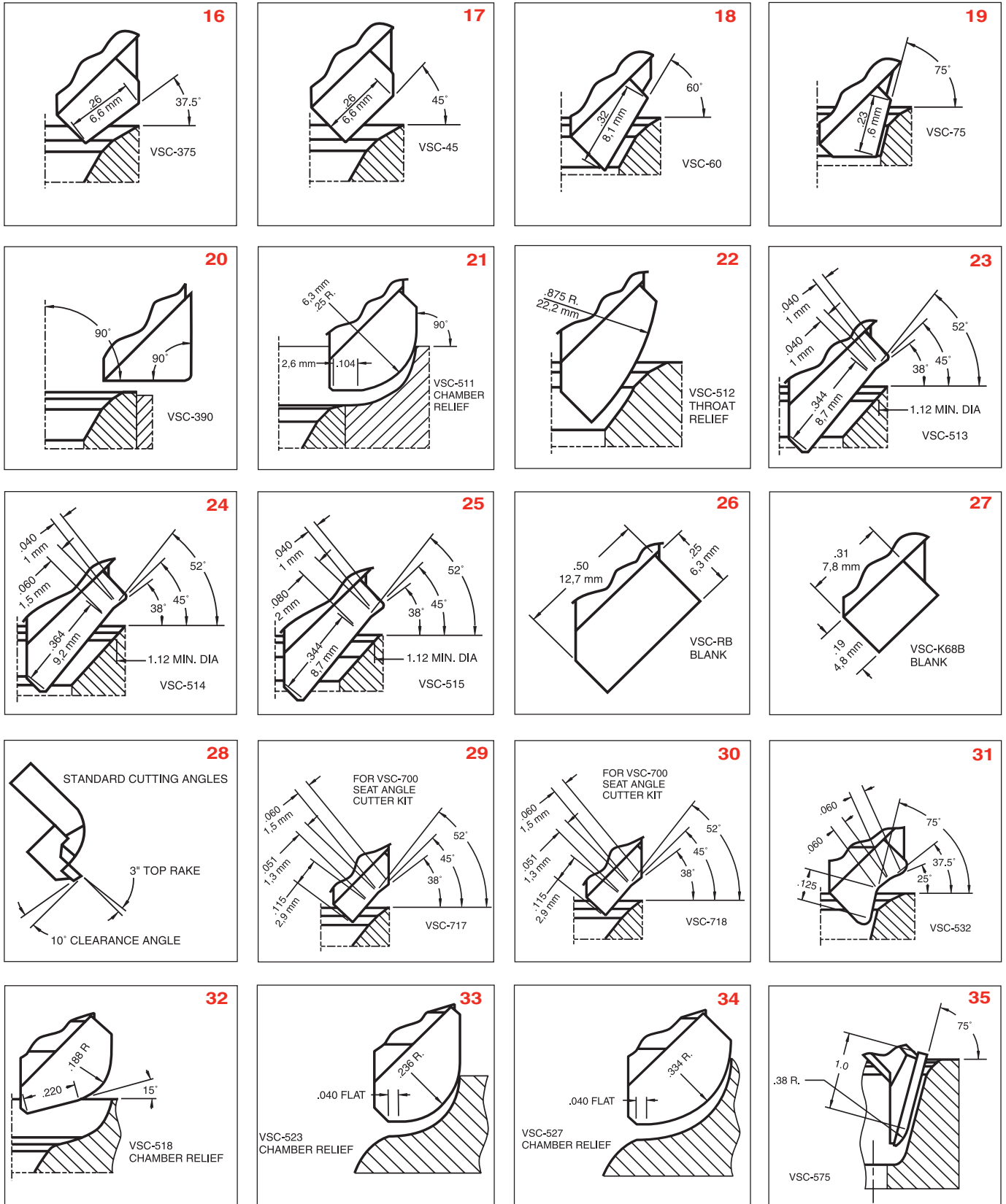

# SGM/VGS Tooling & Accessories

## Repair Parts for VSC-400 Setting Fixture



VSC-440 Upgrade Kit For VSC-400 Includes:

Part No.	Descriptions
PHW-383	Washer
VSC-420A	Ball Plunger
VSC-430A	Pointer Knob
VSC-435A	Pointer Adjustment Knob
VSC-437	Pointer
VSC-438	Pointer Arm

## VGS-320A Ball Drive Adapter



Application: Drives VGS-325, VGS-510, VSC200, VSC-300, VSC-350, SGM-1020, SGM-1025, and SGM-1030 Tool Bodies.

## SHO-965-00L Cutting Oil



1 Quart Bottle (0,95 Liter). Aids in producing a smoother cut. Helps prevent tool buildup.

NOTE: VGS-20657 is still available, however, SHO-965-00L has the same performance with fewer regulatory concerns.

## Tool Bit Assemblies for VGS-500 and VGS-500S Kits

Part No.	Descriptions
VGS-250-15	.25 in. (6,4 mm) x 15 deg
VGS-250-30	.25 in. (6,4 mm) x 30 deg
VGS-312-00	.3125 in. (7,9 mm) x 0 deg
VGS-312-15	.3125 in. (7,9 mm) x 15 deg
VGS-312-30	.3125 in. (7,9 mm) x 30 deg
VGS-312-45	.3125 in. (7,9 mm) x 45 deg
VGS-312-60	.3125 in. (7,9 mm) x 60 deg
VGS-375-00	.375 in. (9,5 mm) x 0 deg
VGS-375-15	.375 in. (9,5 mm) x 15 deg
VGS-375-30	.375 in. (9,5 mm) x 30 deg
VGS-375-45	.375 in. (9,5 mm) x 45 deg
VGS-375-60	.375 in. (9,5 mm) x 60 deg
VGS-500-00	.5 in. (12,7 mm) x 0 deg
VGS-500-15	.5 in. (12,7 mm) x 15 deg
VGS-500-30	.5 in. (12,7 mm) x 30 deg
VGS-500-45	.5 in. (12,7 mm) x 45 deg
VGS-500-60	.5 in. (12,7 mm) x 60 deg
VGS-625-00	.625 in. (15,9 mm) x 0 deg
VGS-625-15	.625 in. (15,9 mm) x 15 deg
VGS-625-30	.625 in. (15,9 mm) x 30 deg
VGS-625-45	.625 in. (15,9 mm) x 45 deg
VGS-625-60	.625 in. (15,9 mm) x 60 deg

# SGM/VGS Tooling & Accessories

## VGS-300 Valve Seat Pocket Cutter Kit 1.500 to 2.250 in. (38,5 - 57,1 mm)



The VGS-300 is used to machine cylinder heads for the installation of new valve seat rings. Replaceable carbide inserts are easily adjusted to size with the micrometer provided, so the proper press fit can be obtained for cast iron or aluminum heads.

Kit Includes:

Part No.	Descriptions
ASPC-1500	Seat Pocket Cutter Head 1.500 -1.687 in. (38,1 - 42,9 mm) Range
ASPC-1687	Seat Pocket Cutter Head 1.687-1.875 in. (42,9 - 47,6 mm) Range
ASPC-1875	Seat Pocket Cutter Head 1.875 - 2.062 in. (47,6 - 52,4 mm) Range
ASPC-2062	Seat Pocket Cutter Head 2.062 - 2.250 in. (52,4 -57,1 mm) Range
VGS-325	Cutter Head Driver for Sunnen .389 in. (9,88 mm) Pilot
VGS-410A	Pocket Cutter Setting Fixture with Setting Standard
PSP-215A	Short Spring
PSP-216A	Long Spring
VSC-509A	Spring Bushing (4)
PWM-5A	Hex T-Wrench

## VGS-300M Valve Seat Pocket Cutter Kit Metric (Sunnen Pilots)

Same as VGS-300, except includes VGS-410MA Pocket Cutter Setting Fixture (metric) instead of VGS-410A (inch).

## VGS-300S Valve Seat Pocket Cutter Kit (Sioux Pilots)

Same as VGS-300, except Cutter Head Driver fits Sioux .385 in. (9,8 mm) pilots.

## SGM-300 Valve Seat Pocket Cutter Kit (Sunnen Pilots)

Same as VGS-300, except without VGS-410A Pocket Cutter Setting Fixture. This kit should be used by customers who have a VGS-410 or SGM-5020 Setting Fixture.

## VSC-725 Cutter Head Driver Assembly

For SVP & CVP pilots. Used with ASPC seat pocket cutters.

## VGS-325 Cutter Head Driver

For use with Sunnen ASPC Cutter Heads. Order VGS-325S for Sioux pilots.



## ASPC-948A Taper Head Wedge Screw



Package of 2.  
Retains the carbide inserts in the following tool heads: ASPC-937 through ASPC-1218, VGS-145 and VGS-245 Spot Facer.

## Seat Pocket Cutter

Part No.	Descriptions
VGS-320A	Drive Adapter
VGS-325	Cutter Head Driver For Sunnen .389" (9,9 mm) Pilot
VGS-325S	Cutter Head Driver For Sioux .385" (9,8 mm) Pilot
VGS-410A	Pocket Cutter Setting Fixture
VGS-410MA	Pocket Cutter Setting Fixture (Metric)
SGM-5020	Pocket Cutter/Valve Seat Cutter Setting Fixture (Inch/Metric)
ASPC-942A	Carbide Insert for ASPC-1218 and Smaller Seat Pocket Cutter Heads (Sold in package of 5 only)
ASPC-944	Wedge For ASPC-942A Inserts
ASPC-949	RH/LH Lock Screw for ASPC-942A Inserts and
VGS-345	Wedges (Package of 2)
ASPC-941A	Carbide inserts for ASPC-1312 and Larger Seat Pocket Cutter Heads (Sold in pkg of 5 only)
ASPC-943A	Wedge for ASPC-941 A Insert
ASPC-947A	RH/LH Lock Screw for ASPC-943A Retainer Wedge (Pkg of 2)
PSP-215A	Short Spring
PSP-216A	Long Spring
VSC-509A	Spring Bushing
PWM-5A	Hex T-Wrench
VGS-20657	Cutting Oil, 1 Quart (0,95 Liter)

### Seat Pocket Cutter Heads Available

ASPC-937	.937" - 1.031" (23,8 mm-26,2 mm)
ASPC-1031	1.031"-1.125" (26,2 mm-28,6 mm)
ASPC-1125	1.125"-1.218" (28,6 mm-30,9 mm)
ASPC-1218	1.218"-1.312" (30,9 mm-33,3 mm)
ASPC-1312	1.312"-1.500" (33,3 mm-38,1 mm)
ASPC-1500*	1.500"-1.687" (38,1 mm-42,8 mm)
ASPC-1687*	1.687"-1.875" (42,8 mm-47,6 mm)
ASPC-1875*	1.875"-2.062" (47,6 mm-52,4 mm)
ASPC-2062*	2.062"-2.250" (52,4 mm-57,1 mm)
ASPC-2250	2.250"-2.437" (57,1 mm-61,9 mm)
ASPC-2437	2.437"-2.625" (61,9 mm-66,7 mm)
ASPC-2625	2.625"-2.812" (66,7 mm-71,4 mm)
ASPC-2812	2.812"-3.000" (71,4 mm-76,2 mm)

\*These cutter heads are supplied in VGS-300 Seat Pocket Cutter Kit.

## Bounce Springs



Use under VGS, VSC, ASPC and SGM Cutter Bodies.

Part No.	Descriptions
PSP-212A	Spring, Short (SVP)
PSP-213A	Spring, Long (SVP)
VSC-709A	Spring Bushing (1)
PSP-215A	Spring, Short (VS)
PSP-216A	Spring, Long (VS)
VSC-509A	Spring Bushing (1)

## ASPC-947A Lock Screw



LH/RH Thread. Locks ASPC-943A, VSC-302 and VSC-202 Wedges in VSC-200, VSC-300, VSC-350 and 1-1.3125 in. (49,2 mm) and larger Seat Pocket Cutters. (Package of 2).

## Carbide Inserts VGS/SGM Tooling

Part No.	Descriptions
ASPC-941A	For ASPC-1312 and larger
ASPC-942A	For ASPC-1218 and smaller

# SGM/VGS Tooling & Accessories

## VS Pilots = Hardened Steel Pilots

### .389" Top Diameter (9,88 mm)

#### "E" LENGTH

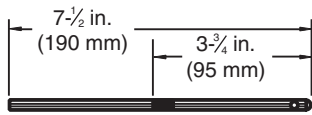

#### "L" LENGTH

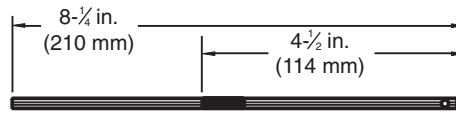

### VS-85A Pilot Insertion/ Removal Tool

Note: For maximum accuracy on valve seats with valve guides smaller than .248 in. (6,32 mm), use the VSC-700 kit shown on page 25.

DIAMETER			DIAMETER			DIAMETER			DIAMETER		
in.	mm	PILOT No.	in.	mm	PILOT No.	in.	mm	PILOT No.	in.	mm	PILOT No.
.248	6,30	VS-248E	.320	8,13	VS-320E	.371	9,42	VS-371E	.435	11,05	VS-435L
.249	6,32	VS-249E	.321	8,15	VS-321E	.372	9,45	VS-372E	.436	11,07	VS-436E
.250	6,35	VS-250E	.322	8,18	VS-322E	.373	9,47	VS-373E	.436	11,07	VS-436L
.251	6,37	VS-251E	.323	8,20	VS-323E	.374	9,50	VS-374E	.437	11,10	VS-437E
.252	6,40	VS-252E	.324	8,23	VS-324E	.375	9,53	VS-375E	.437	11,10	VS-437L
.255	6,48	VS-255E	.325	8,26	VS-325E	.376	9,55	VS-376E*	.438	11,13	VS-438E
.256	6,50	VS-256E	.326	8,28	VS-326E	.377	9,57	VS-377E*	.438	11,13	VS-438L
.257	6,53	VS-257E	.328	8,33	VS-328E	.378	9,60	VS-378E*	.451	11,45	VS-451L
.259	6,58	VS-259E	.332	8,43	VS-332E	.379	9,63	VS-379E*	.452	11,48	VS-452L
.260	6,60	VS-260E	.334	8,48	VS-334E	.380	9,65	VS-380E*	.453	11,51	VS-453L
.261	6,63	VS-261E	.335	8,51	VS-335E	.381	9,68	VS-381E	.454	11,53	VS-454L
.274	6,96	VS-274E	.336	8,53	VS-336E	.385	9,78	VS-385E	.472	11,99	VS-472E
.275	6,99	VS-275E	.339	8,61	VS-339E	.388	9,86	VS-388E	.473	12,01	VS-473E
.276	7,01	VS-276E	.340	8,64	VS-340E*	.389	9,88	VS-389E	.474	12,04	VS-474E
.277	7,04	VS-277E	.341	8,66	VS-341E*	.393	9,98	VS-393E	.497	12,62	VS-497L
.281	7,14	VS-281E	.342	8,69	VS-342E*	.394	10,01	VS-394E	.498	12,65	VS-498E
.282	7,16	VS-282E	.343	8,71	VS-343E	.395	10,03	VS-395E	.498	12,65	VS-498L
.283	7,19	VS-283E	.344	8,74	VS-344E	.403	10,24	VS-403E	.499	12,67	VS-499E
.288	7,32	VS-288E	.345	8,76	VS-345E	.404	10,26	VS-404E	.499	12,67	VS-499L
.309	7,85	VS-309E	.346	8,79	VS-346E	.405	10,29	VS-405E	.500	12,70	VS-500E
.310	7,87	VS-310E*	.353	8,97	VS-353E	.406	10,31	VS-406E	.500	12,70	VS-500L
.311	7,90	VS-311E*	.354	8,99	VS-354E	.407	10,34	VS-407E	.501	12,73	VS-501E
.312	7,92	VS-312E*	.355	9,02	VS-355E	.417	10,59	VS-417E	.502	12,75	VS-502E
.313	7,95	VS-313E	.356	9,04	VS-356E	.418	10,62	VS-418E	.503	12,78	VS-503E
.314	7,98	VS-314E	.358	9,09	VS-358E	.419	10,64	VS-419E	.504	12,80	VS-504E
.315	8,00	VS-315E	.359	9,12	VS-359E	.432	10,97	VS-432E	.505	12,83	VS-505E
.316	8,03	VS-316E	.361	9,17	VS-361E	.433	11,00	VS-433E	.506	12,85	VS-506E
.317	8,05	VS-317E	.362	9,19	VS-362E	.434	11,02	VS-434E			
.318	8,08	VS-318E	.370	9,39	VS-370E	.435	11,05	VS-435E			

\*Pilots standard in VS-300E Pilot Kit

Pilots available on special order: VS-3415E .3415 in. (8,67 mm) VS-3395E .3395 in. (8,62 mm) VS-3425E .3425 in. (8,70 mm)  
VS-3405E .3405 in. (8,65 mm) VS-3435E .3435 in. (8,72 mm)

### VS-300E Valve Guide Pilot Kit

for Harley-Davidson® Heads

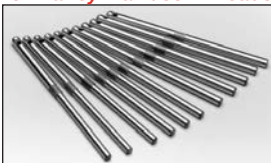

A convenient valve guide pilot kit for the most popular Harley® guide sizes.

\*See above chart for sizes in kit.



# SGM/VGS Tooling & Accessories

## CP Pilots = Carbide Pilots



### SGM-1100 Pilot Insertion/ Removal Tool

(Must order when using CP Pilots.)

**.389" Top Diameter  
(9,88 mm)**

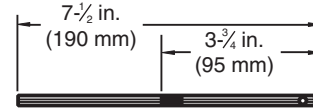

**"CP"  
LENGTH**

DIAMETER			DIAMETER			DIAMETER			DIAMETER		
in.	mm	PILOT No.	in.	mm	PILOT No.	in.	mm	PILOT No.	in.	mm	PILOT No.
.215	5,46	CP-215E*	.275	6,99	CP-275E*	.315	8,00	CP-315E*	.354	8,99	CP-354E*
.216	5,48	CP-216E*	.276	7,01	CP-276E*	.316	8,03	CP-316E*	.372	9,45	CP-372E*
.217	5,51	CP-217E*	.310	7,87	CP-310E*	.317	8,05	CP-317E*	.373	9,47	CP-373E*
.235	5,96	CP-235E*	.311	7,90	CP-311E*	.341	8,66	CP-341E*	.374	9,50	CP-374E*
.236	6,00	CP-236E*	.312	7,92	CP-312E*	.342	8,69	CP-342E*	.375	9,53	CP-375E*
.237	6,01	CP-237E*	.313	7,95	CP-313E*	.343	8,71	CP-343E*			
.260	6,60	CP-260E*	.314	7,98	CP-314E*	.344	8,74	CP-344E*			

\*Available from Stock. All others Special Order. Allow 6 weeks for delivery, plus additional cost.

Pilots available on special order:	CP-3115E .3115 in. (7,91 mm)	CP-3395E .3395 in. (8,62 mm)	CP-3425E .3425 in. (8,70 mm)
CP-3095E .3095 in. (7,86 mm)	CP-3125E .3125 in. (7,94 mm)	CP-3405E .3405 in. (8,65 mm)	CP-3435E .3435 in. (8,72 mm)
CP-3105E .3105 in. (7,89 mm)	CP-3135E .3135 in. (7,96 mm)	CP-3415E .3415 in. (8,67 mm)	

## Pilots For SGM-700 and VSC-700, 3-Angle Seat Cutter Kits



**.236" Top Diameter (5,99 mm)**

### SGM-1200 Pilot Insertion/ Removal Tool

**"CVP" LENGTH**

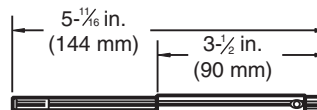

DIAMETER			DIAMETER			DIAMETER			DIAMETER		
in.	mm	PILOT No.	in.	mm	PILOT No.	in.	mm	PILOT No.	in.	mm	PILOT No.
.157	4,00	CVP-157	.197	5,00	CVP-197	.235	5,97	CVP-235	.257	6,53	CVP-257
.158	4,01	CVP-158	.198	5,03	CVP-198	.236	5,99	CVP-236	.258	6,55	CVP-258
.176	4,47	CVP-176	.215	5,46	CVP-215	.237	6,02	CVP-237	.259	6,58	CVP-259
.177	4,50	CVP-177	.216	5,48	CVP-216	.238	6,05	CVP-238	.260	6,60	CVP-260
.178	4,52	CVP-178	.217	5,51	CVP-217	.239	6,07	CVP-239	.276	7,01	CVP-276
.195	4,95	CVP-195	.218	5,54	CVP-218	.240	6,09	CVP-240	.277	7,03	CVP-277
.196	4,98	CVP-196	.234	5,94	CVP-234	.256	6,50	CVP-256			

# SGM/VGS Tooling & Accessories



## VGS-20956 Drill, Reamer and Spot Facer Kit

Kit Includes:

Part No.	Descriptions
VGS-140A	Tapered Spindle Adapters (3)
VGS-130A	Drill Chuck with Adapter
VGS-152A	.490" (12,45 mm) Drill with .343" (8,71 mm) Pilot
VGS-153A	.490" (12,45 mm) Drill with .371" (9,42 mm) Pilot
VGS-156A	.490" (12,45 mm) Drill with .312" (7,92 mm) Pilot
VGS-162A	.500" (12,70 mm) Reamer with .490" (12,45 mm) Pilot
VGS-145A	.75" (19,05 mm) Spot Facer Assembly
VGS-171	.312" (7,92 mm) Spot Facer Pilot
VGS-172	.343" (8,71 mm) Spot Facer Pilot
VGS-173	.375" (9,52 mm) Spot Facer Pilot
VGS-174A	.437" (11,10 mm) Spot Facer Pilot
VGS-176	.496" (12,6 mm) Spot Facer Pilot
PWM-12A	Tee Handle Wrench

## Accessories & Replacement Items for Spot Face

Part No.	Descriptions
VGS-140A	Tapered Spindle Adapter
VGS-130A	Drill Chuck with Adapter
VGS-145A	.75" (19,05 mm) Spot Facer Assembly
ASPC-942A	Carbide Inserts for VGS-145A (Pkg of 5)
VGS-245A	1.125" (28,6 mm) Spot Facer Assembly
ASPC-952A	Carbide Inserts for VGS-245A (Pkg of 5)
ASPC-948A	Insert Retainer Screws for VGS-145A & VGS-245A Spot Facer Assemblies (Set of 2)
VGS-345	1.375" (35 mm) Spot Facer Assembly
SGM-1153	Carbide Inserts for VGS-345
SGM-1152	Wedge for VGS-345
ASPC-949	RH/LH Lock Screw for ASPC-942A Inserts and VGS-345 Wedges
AN-320	Pilot Retainer Screw (Pkg of 4)
VGS-177A	.256" (6,5 mm) Spot Facer Pilot
VGS-178A	.275" (7 mm) Spot Facer Pilot
VGS-171A	.312" (7,92 mm) Spot Facer Pilot
VGS-172A	.343" (8,71 mm) Spot Facer Pilot
VGS-179A	.365" (9,27 mm) Spot Facer Pilot
VGS-173A	.375" (9,52 mm) Spot Facer Pilot
VGS-174A	.437" (11,10 mm) Spot Facer Pilot
VGS-176A	.500" (12,70 mm) Spot Facer Pilot
VGS-152A	.490" (12,45 mm) Drill with .343" (8,71 mm) Pilot
VGS-153A	.490" (12,45 mm) Drill with .371" (9,42 mm) Pilot
VGS-156A	.490" (12,45 mm) Drill with .312" (7,92 mm) Pilot
VGS-243A	.550" (13,97 mm) Drill with .341" (8,66 mm) Pilot
VGS-162A	.500" (12,70 mm) Reamer with .490" (12,45 mm) Pilot
VGS-163A	.625" (15,87 mm) Reamer with .609" (15,47 mm) Pilot
VGS-244A	.563" (14,30 mm) Reamer with .549" (13,94 mm) Pilot

## VGS-20960 Valve Seat Driver Kit



Kit Includes:

Part No.	Description
VGS-440A	Seat Ring Driver Adapter, Air Hammer
VGS-430A	Seat Ring Driver Adapter, Manual

### Seat Ring Driver Adapter Rings

VGS-451A	.925 x 1.125" (23,49 x 28,57 mm)
VGS-452A	1.25 x 1.375" (31,75 x 34,92 mm)
VGS-453A	1.50 x 1.625" (38,10 x 41,27 mm)
VGS-454A	1.75 x 1.875" (44,45 x 47,62 mm)
VGS-455A	2.00 x 2.125" (50,80 x 53,97 mm)
VGS-456A	2.25 x 2.375" (57,15 x 60,32 mm)



## B-200L Press Fit Lubricant

High pressure lubricant in .5 pint brush applicator bottle. Prevents galling and reduces ram pressure. Assures smooth, easy assembly of press fit parts. Packaged in brush applicator bottle. Sold individually.

## B-200 Press Fit Lubricant

Same as B-200L, but in a spray can. Seven ounce cans. Sold in packages of 12.

## VGS-140A Adapter



Application: Adapts Drill, Reamer and Spot Facer Tooling to VGS and SGM Spindle. Replacement Set Screw: PHS-198.

## Carbide Inserts For VGS/SGM Spot Facers

Part No.	Descriptions
ASPC-942A	Carbide inserts for VGS-145A
ASPC-952A	Carbide inserts for VGS-245A
SGM-1153	Carbide inserts for VGS-345

## VGS-20518 Valve Guide Kit

For installing .5625 OD x .3437 in. ID (14,3 x 8,7 mm) valve guides.

Kit Includes:

Part No.	Descriptions
VGS-243A	.550 in. (13,97 mm) Drill with .341 in. (8,66 mm) Pilot
VGS-244A	.563 in. (14,30 mm) Reamer with .549 in. (13,94 mm) Pilot

# SGM/VGS Tooling & Accessories

## VGS-660 Electronic Level



The VGS-660 Electronic Level is a precision measurement sensor that provides wide angular range with excellent lin-

earity. The readout unit contains a standard nine-volt battery which provides power for the system electronics and liquid crystal display. Angular position is displayed digitally to within 0.1 of a degree.

Linear Range	±45°
Resolution	.1°
Linearity - Null to 10°	±.1°
10° to 45°	±1% of Reading
Voltage Supply	Std. 9v Battery

Kit Includes:

Part No.	Descriptions
VGS-661	Level with Liquid Crystal Display
VGS-667	Mounting Bracket with Hardware
VGS-6613A	Coupler
VGS-6612A	Cable

## VGS-130A Drill Chuck

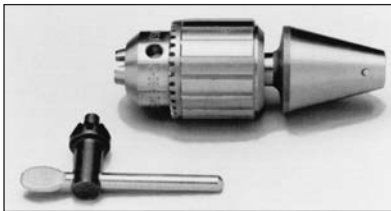

Drill chuck with 0-.5 in. (0,0-12,7 mm) capacity for drilling, reaming, and other machining applications. Used with VGS-20 and SGM 1500 Valve Guide and Seat Machine and includes integral quick change adapter and chuck key.

## SGM-1050 Extended Collet Chuck



For drilling, tapping, reaming, and bronze liner installation. Insures positive gripping of tools with minimum runout. For SGM-1500 & VGS-20.

Includes:

- Collet Chuck Adapter (1)
- .75 in. Wrench (1)
- 30 mm Wrench (1)

(Collets must be ordered separately.)

NOTE: SGM-1050 is 1 in. (25,4 mm) longer than VGS-1800A.

## VGS-1800A Collet Chuck

For use with VGS-20 only.



For drilling, tapping, reaming, and bronze liner installation. Insures positive gripping of tools with minimum runout for increased accuracy.

Includes:

- Collet chuck with adapter (1)
- .75 in. wrench (1)
- 30 mm wrench (1)

(Collets must be ordered separately)

## VC-200 Collet Set

Set includes the most popular collet sizes for the VGS-1800A and SGM 1500 Collet Chuck. Collets may be ordered individually if desired. Set includes one each of collets listed:

Part No.	Diameter Range
VC-276	.276 - .315 in. (7,01 - 8,00 mm)
VC-315	.315 - .354 in. (8,00 - 8,99 mm)
VC-354	.354 - .394 in. (8,99 - 10,00 mm)
VC-433	.433 - .472 in. (10,99 - 11,98 mm)
VC-472	.472 - .512 in. (11,98 - 13,00 mm)

A complete line of collets not listed above are available on a special order basis from .019-.433 inch (0,48-10,99 mm) diameter range. For information call Customer Service toll free.

## VGS-1450A Adjustable Level Assembly



Part No.	Descriptions
VGS-1455A	Vial and Sleeve Assembly*
VGS-1458A	Vial only

\*Recommended for immediate repair.

# SGM/VGS Tooling & Accessories

## Hex T-Wrench



Part No.	Descriptions	Applications
PWM-5A	.0937 in. (2,38 mm)	Spot Facer Pilot, ASPC Head, VSC Bodies
PWMM-10A	.098 in. (2,5 mm)	Diameter adjustment on SGM Insert Holders

## VGS-1750 and VGS-1750M Seat Depth Indicator Kits



The Sunnen VGS-1750 and VGS-1750M Seat Depth Indicators are designed for installation on Sunnen Valve Guide & Seat Machines, models VGS-19 and VGS-20. The VGS-1750 is calibrated in inches and the VGS-1750M is for metric use.

### Features:

- Helps operator control valve stem installed height.
- Aids in maintaining consistent combustion chamber volume.
- Enables the machinist to cut seats and seat pockets to an exact depth dimension.

*Note: This kit is retrofittable to machines after serial number 1271, without modification to the machine. For serial numbers prior to 1271, a drill and tap operation on the face casting and trimming the belt shroud is required. In addition to the VGS-1750 indicator kit, a VGS-1265A Lift Cable Plate Assembly must be ordered.*

Call the customer service department for details.

### Kit Includes:

Part No.	Descriptions
VGS-1756A	Dial Indicator (VGS-1756M for metric)
VGS-1757A	Indicator Clam
VGS-1758	Post Support
VGS-1759A	Post

## VGS-2682 Stud Level Pin

Insures proper cylinder head alignment to repair broken studs or other holes in areas where a guide pilot cannot be used.



# SGM/VGS Tooling & Accessories

## VSC-100 Tool Sharpener Fixture Kit



The VSC-100, when used in conjunction with Sunnen's TS-100 Precision Tool Sharpener, sharpens cutters in the body eliminating the need to reset the tool each time.

Part No.	Descriptions
<b>VSC-100</b>	Comes complete with the following:
<b>VSC-101</b>	VSC Tool In-Body Sharpening Fixture
<b>VSC-103</b>	Guide Pin (.236 in.) for VSC-710 Cutter Bodies
<b>VSC-105</b>	Guide Pin (.389 in.) for VSC Cutter Bodies
<b>VSC-110</b>	600 grit face/edge diamond wheel (6 in.)

## SGM-5530 Tool Sharpener Retrofit Kit

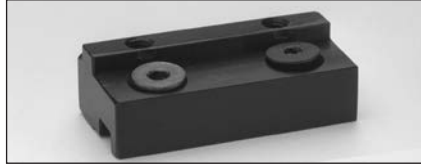

SGM-5530 allows customers using the VSC-100 Tool Sharpening Fixture with VSC tooling to easily convert to sharpening SGM-style tooling with extension bushings.

## Replacement Wheels & Accessories for TS-100 A/K

Part No.	Descriptions
<b>TS-120A</b>	Diamond Wheel, 260 Grit
<b>TS-121A</b>	Diamond Wheel, 360 Grit
<b>TS-122A</b>	Diamond Wheel, 600 Grit
<b>TS-123A</b>	Diamond Wheel, 1200 Grit
<b>TS-125A</b>	Wheel Cleaning Stick
<b>TS-126A</b>	Wetting Agent (package of 3)
<b>TS-128A</b>	Diamond Spray
<b>VSC-50</b>	VSC-500 Tool Sharpening Fixture
<b>VSC-55</b>	VSC-500 (Used to grind straight angles on VSC cutters)

## VSC-55 Tool Sharpening Fixture

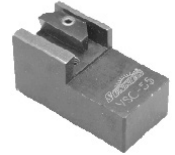

Similar to VSC-50. Used to "off-hand" grind any angle desired on VSC single angle cutters or cutter blanks.



# CHW 40/50 Cylinder Head Workstation

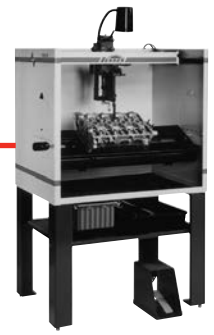

**Note: CHW 40/50 Workstation is no longer in production. Supplies and accessories are still available.**

## Accessories and Supplies

Part No.		Descriptions
① VGS-1487A	4	Head Clamp Spacer (Pkg. Of 1)
② CHW-570A	2	Quick Clamp (Pkg. Of 1)
③ CHW-560A	1	Magnetic Wand
④ CHW-550A	1	Magnetic Bubble Level
⑤ CHW-535A	1	Setup Standard
⑥ CHW-575A	1	Clamp Screw
⑦ CHW-626A	1	Press Foot #2.875" OD X .635" ID (22,2 X 16,1 mm)
⑦ CHW-627A	1	Press Foot #31.0" OD X .732" ID (25,4 X 18,6 mm)
⑦ CHW-628A	1	Press Foot #41.125" OD X .907" ID (28,5 X 23,0 mm)
⑦ CHW-629A	1	Press Foot #51.312" OD X .937" ID (33,3 X 23,7 mm)
⑦ CHW-630A	1	Press Foot #61.5" OD X 1.125" ID (38,1 X 28,5 mm)
⑧ PWM-92A	1	T-Handle Wrench

**NOT SHOWN:**

CHW-441A Foam Pad



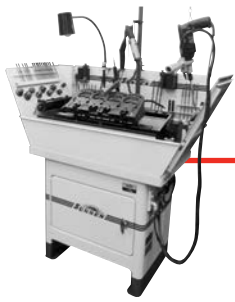

# HS-60 Valve Job Power Bench

## Accessory Kits and Tooling for Valve Guide Sizing and Valve Seating

**Note: HS-60 is no longer in production.  
Supplies and accessories are still available.**

### VS-150 Wheel Holder for Valve Seating

Mounts the VS Series diamond wheels for seat grinding.  
(Must be ordered separately.)

*Important: For most efficient use, order at least three wheel holders  
(one for each seating angle).*

### VS-85A Pilot Insertion/Removal Tool

Used to install VS Pilots into valve guides.



### VS-65 Flexible Driver Replacement Kit

For VS-50 and VS-150  
Wheel Holders.

*PHW-175A Flexible Washer*



# HS-60 Diamond Wheels for Valve Seating

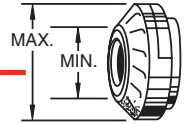

15° Diamond Wheels	Projected Wheel Diameter Range			
	Inches		mm	
	Min.	Max.	Min.	Max.
VS-875-15D3	.592	.817	15,04	20,75
VS-1000-15D3	.592	.942	15,04	23,93
VS-1125-15D3	.627	1.067	15,92	27,10
VS-1250-15D3	.752	1.192	19,10	30,28
VS-1375-15D3	.905	1.317	22,99	33,45
VS-1500-15D3	.905	1.442	22,99	36,63
VS-1625-15D3	.903	1.567	22,94	39,80
VS-1750-15D3	1.028	1.692	26,11	42,98
VS-1875-15D3	1.153	1.817	29,29	46,15
VS-2000-15D3	1.278	1.942	32,46	49,33
VS-2125-15D3	1.403	2.067	35,64	52,50
VS-2250-15D3	1.528	2.192	38,81	55,68
VS-2375-15D3	1.653	2.317	41,99	58,85
VS-2500-15D3	1.778	2.442	45,16	62,03
VS-2625-15D3	1.903	2.567	48,34	65,20

30° Diamond Wheels	Projected Wheel Diameter Range			
	Inches		mm	
	Min.	Max.	Min.	Max.
VS-875-30D3	.592	.817	15,04	20,75
VS-1000-30D3	.592	.942	15,04	23,93
VS-1125-30D3	.627	1.067	15,92	27,10
VS-1250-30D3	.752	1.192	19,10	30,28
VS-1375-30D3	.905	1.317	22,99	33,45
VS-1500-30D3	.905	1.442	22,99	36,63
VS-1625-30D3	.976	1.567	24,79	39,80
VS-1750-30D3	1.100	1.692	27,94	42,98
VS-1875-30D3	1.225	1.817	31,12	46,15
VS-2000-30D3	1.350	1.942	34,29	49,33
VS-2125-30D3	1.475	2.067	37,47	52,50
VS-2250-30D3	1.600	2.192	40,64	55,68
VS-2375-30D3	1.725	2.317	43,82	58,85
VS-2500-30D3	1.850	2.442	46,99	62,03
VS-2625-30D3	1.975	2.567	50,17	65,20

45° Diamond Wheels	Projected Wheel Diameter Range			
	Inches		mm	
	Min.	Max.	Min.	Max.
VS-875-45D3	.571	.817	14,50	20,75
VS-1000-45D3	.571	.942	14,50	23,93
VS-1125-45D3	.606	1.067	15,39	27,10
VS-1250-45D3	.731	1.192	18,57	30,28
VS-1375-45D3	.905	1.317	22,99	33,45
VS-1500-45D3	.962	1.442	24,43	36,63
VS-1625-45D3	1.087	1.567	27,61	39,80
VS-1750-45D3	1.212	1.692	30,78	42,98
VS-1875-45D3	1.337	1.817	33,96	46,15
VS-2000-45D3	1.462	1.942	37,13	49,33
VS-2125-45D3	1.587	2.067	40,31	52,50
VS-2250-45D3	1.712	2.192	43,48	55,68
VS-2375-45D3	1.837	2.317	46,66	58,85
VS-2500-45D3	1.962	2.442	49,83	62,03

60° Diamond Wheels	Projected Wheel Diameter Range			
	Inches		mm	
	Min.	Max.	Min.	Max.
VS-875-60D3	.575	.835	14,61	21,21
VS-1000-60D3	.575	.960	14,61	24,38
VS-1125-60D3	.628	1.085	15,95	27,56
VS-1250-60D3	.753	1.210	19,13	30,73
VS-1375-60D3	.905	1.335	22,99	33,91
VS-1500-60D3	.950	1.460	24,13	37,08
VS-1625-60D3	1.075	1.585	27,31	40,26
VS-1750-60D3	1.200	1.710	30,48	43,43
VS-1875-60D3	1.325	1.835	33,66	46,61
VS-2000-60D3	1.450	1.960	36,83	49,78
VS-2125-60D3	1.575	2.085	40,01	52,96
VS-2250-60D3	1.700	2.210	43,18	56,13
VS-2375-60D3	1.825	2.335	46,36	59,31
VS-2500-60D3	1.950	2.460	49,53	62,48

30° Extra Fine Grit Diamond Wheels	Projected Wheel Diameter Range			
	Inches		mm	
	Min.	Max.	Min.	Max.
VS-875-30D8	.592	.817	15,04	20,75
VS-1000-30D8	.592	.942	15,04	23,93
VS-1125-30D8	.627	1.067	15,92	27,10
VS-1250-30D8	.752	1.192	19,10	30,28
VS-1375-30D8	.905	1.317	22,99	33,45
VS-1500-30D8	.905	1.442	22,99	36,63
VS-1625-30D8	.976	1.567	24,79	39,80
VS-1750-30D8	1.100	1.692	27,94	42,98
VS-1875-30D8	1.225	1.817	31,12	46,15
VS-2000-30D8	1.350	1.942	34,29	49,33
VS-2125-30D8	1.475	2.067	37,47	52,50
VS-2250-30D8	1.600	2.192	40,64	55,68
VS-2375-30D8	1.725	2.317	43,82	58,85

45° Extra Fine Grit Diamond Wheels	Projected Wheel Diameter Range			
	Inches		mm	
	Min.	Max.	Min.	Max.
VS-875-45D8	.571	.817	14,50	20,72
VS-1000-45D8	.571	.942	14,50	23,93
VS-1125-45D8	.606	1.067	15,39	27,10
VS-1250-45D8	.731	1.192	18,57	30,28
VS-1375-45D8	.905	1.317	22,99	33,45
VS-1500-45D8	.962	1.442	24,43	36,63
VS-1625-45D8	1.087	1.567	27,61	39,80
VS-1750-45D8	1.212	1.692	30,78	42,98
VS-1875-45D8	1.337	1.817	33,96	46,15
VS-2000-45D8	1.462	1.942	37,13	49,33
VS-2125-45D8	1.587	2.067	40,31	52,50
VS-2250-45D8	1.712	2.192	43,48	55,68
VS-2375-45D8	1.837	2.317	46,66	58,85
VS-2500-45D8	1.962	2.442	49,83	62,03

NOTE: Special angle VS wheels and grit sizes are available on request. Call Sunnen customer service for price and delivery.

# HS-60 Honing Tools

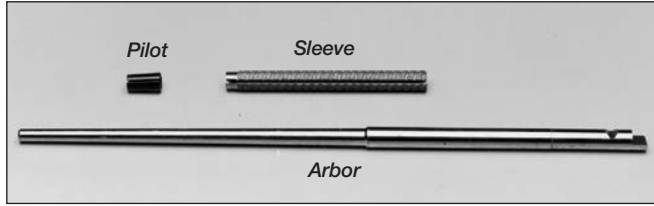

## Diamond Sizing Tools

(Each tool includes arbor, sleeve and pilot.)†

Tool No.	Size		Finish Diameter Range	
	Inches	mm	Inches	mm
V8A-235-D5*	-	6	.233-.238	5,92-6,05
V8A-250-D5*	.25	-	.248-.253	6,30-6,43
V8A-260-D5*	-	-	.258-.263	6,55-6,68
VG-275-D5*†	-	7	.273-.278	6,93-7,06
VG-315-D5**	.3125	8	.310-.320	7,87-8,13
VG-334-D5**	-	8,5	.329-.339	8,36-8,61
VG-344-D5**	.3437	-	.339-.349	8,61-8,86
VG-354-D5**	-	9	.349-.359	8,86-9,12
VG-374-D5**	.375	9,5	.369-.379	9,37-9,63
VG-394-D5**	-	10	.389-.399	9,88-10,13
VG-433-D5**	-	11	.428-.438	10,87-11,13
VG-438-D5**	.4375	-	.433-.443	11,00-11,25
VG-472-D5**	-	12	.467-.477	11,86-12,12

\* These tools require special A810F Sleeve Adjusting/Removal Tool. (Order separately.)

\*\* These tools require standard HS-510A Sleeve Adjusting/Removal Tool.

† VG-275-D5 does not require a pilot.

## Components for Diamond Sizing Tools

Complete Diamond Hone consists of one each Arbor, Sleeve and Pilot.

### Arbor

	Component of
A8AM	V8A-235-D5, V8A-250-D5, V8A-260-D5
A8BM	VG-275-D5
VG-315-30A	VG-315D5 & VG-334D5
VG-344-30A	VG-344D5 & VG-354D5
VG-374-30A	VG-374D5, VG-394D5 & VG-433D5
VG-438-30A	VG-438D5 & VG-472D5

### Diamond Sleeve

	Component of	Pilot	Component of
A8A-235D5	V8A-235D5	A8A-235P	V8A-235D5
A8A-250D5	V8A-250D5	A8A-250P	V8A-250D5
A8A-260D5	V8A-260D5	A8A-260P	V8A-260D5
VG-275-20D5	VG-275D5	Not required	
VG-315-20D5	VG-315D5	VG-315-PA	VG-315D5
VG-334-20D5	VG-334D5	VG-334-PA	VG-334D5
VG-344-20D5	VG-344D5	VG-344-PA	VG-344D5
VG-354-20D5	VG-354D5	VG-354-PA	VG-354D5
VG-374-20D5	VG-374D5	VG-374-PA	VG-374D5
VG-394-20D5	VG-394D5	VG-394-PA	VG-394D5
VG-433-20D5	VG-433D5	VG-433-PA	VG-433D5
VG-438-20D5	VG-438D5	VG-438-PA	VG-438D5
VG-472-20D5	VG-472D5	VG-472-PA	VG-472D5

# HS-60 Accessories & Supplies

## Accessory Kits and Tooling for Valve Guide Sizing and Valve Seating

### A-810F Sleeve Adjusting/Removal Tool

Must be ordered separately for use with diamond sizing tools .275" (7 mm) diameter and smaller.



### HS-572A Brush

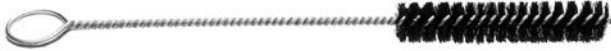

Removes dirt and scale prior to pilot insertion.

### Honing Oil



Available in 5-gallon (18,9 liter) pails. HS-60 requires 10 gallons minimum.

### MB-30-5

Recommended for all valve guide and seat reconditioning and general honing. Required when extra-fine grit diamond wheels are used in valve seat reconditioning and when sizing bronze guides.

### MAN-845-5

For valve guide reconditioning, most valve seat reconditioning, and other general honing.

### PHW-183A Anti Lock Washer

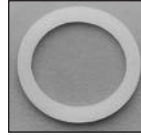

Allows easy removal of VS wheels after use.

### HS-450A Filter Elements



Lines HS-60 honing stand filter basket. Packages of 5.

### HS-430A



Quick Disconnect for HS drills. Requires .5-20 threads.

### HS-519A Filter Clips



Secures HS-450A filter elements to HS-60 filter basket. Packages of 4.

### HS-15 Accessory Lamp



# Pilots for HS Power Bench

---

DIAMETER			DIAMETER			DIAMETER			DIAMETER		
in.	mm	PILOT No.	in.	mm	PILOT No.	in.	mm	PILOT No.	in.	mm	PILOT No.
.214	5,44	VS-214	.236	6,00	VS-236	.277	7,04	VS-277	.316	8,03	VS-316
.215	5,46	VS-215	.237	6,02	VS-237	.278	7,06	VS-278	.352	8,94	VS-352
.216	5,49	VS-216	.258	6,55	VS-258	.279	7,09	VS-279	.354	8,99	VS-354
.217	5,51	VS-217	.275	6,99	VS-275	.280	7,11	VS-280	.394	10,01	VS-394
.234	5,94	VS-234	.276	7,01	VS-276	.313	7,95	VS-313	.396	10,06	VS-396
.235	5,97	VS-235									

*NOTE: These pilots are only to be used with Sunnen HS-60 Power Bench. Using these pilots with a seat and guide machine will give less than expected results.*

*IMPORTANT: For best efficiency, at least four pilots should be ordered for each diameter required.*

# CRG Cap and Rod Grinder

## Accessories and Supplies



**Note: Cap and Rod Grinders are no longer in production.  
Supplies and accessories are still available.**

### CRG-1145 Clamp Conversion Kit



The new improved Clamp Assembly now on Sunnen CRG-920 Heavy Duty Cap and Rod Grinder. Handles large after-market caps up to 9.200". Is designed for converting and upgrading older model CRG-750 and up Grinders.

### CRG-780/920 Replacement Parts

Part No.	Description	Ship Wt.
<b>CRG-801</b>	Grinding Wheel 6" (152 mm) diameter For Aluminum or Hard Steel Caps	3.25 lbs. (1,5 kg)
<b>CRG-803</b>	Grinding Wheel 6" (152 mm) diameter Standard	3.25 lbs. (1,5 kg)
<b>CRG-805</b>	Grinding Wheel 6" (152 mm) diameter One grade harder than CRG-803, for narrow rods and caps	3.25 lbs. (1,5 kg)
<b>CRG-809</b>	Grinding Wheel 6" (152 mm) diameter For titanium rods	3.25 lbs. (1,5 kg)
<b>CRG-330A</b>	Diamond Wheel Dresser	.75 lb. (.34 kg)
<b>CRG-328A</b>	Diamond Dresser Point (included with CRG-330A)	.5 lb. (.23 kg)
<b>CRG-960A</b>	Rod Clamping Fixture	13.5 lbs. (6,1 kg)
<b>LBN-427A</b>	Cleaning Brush	.5 lb. (.23 kg)
<b>CRG-299D</b>	Toggle Switch, On/Off	.5 lb. (.23 kg)
<b>CRG-996A</b>	Wrench, Wheel Flange Nut	.25 lb. (.11 kg)
<b>CRG-1050</b>	Test Block	.75 lb. (1,5 kg)
<b>Replacement Wheels for CRG-500 (not illustrated)</b>		
<b>CRG-305</b>	Grinding Wheel 4" (101 mm) diameter	1.5 lbs. (.68 kg)

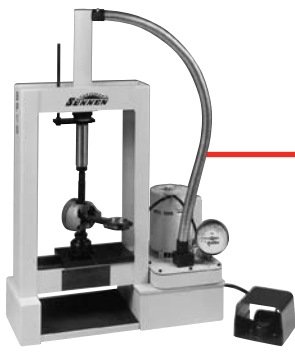

## BP-10 Press

### Off-The-Shelf Tooling Kits and Accessories For All Applications

**Note: The BP-10 Press is no longer in production.  
Supplies and accessories are still available.**

#### BP-416 Gage Kit (optional)



Indicates pressure applied during use of BP-10 press. Gage capacity 10 tons. Kit includes special high pressure fitting.

#### BP-10 Press Replacement Parts

Part No.	Description
BP-118A	Gage Crystal
PSP-505A	Spring, Handle Return
CRG-299D	Toggle Switch, On/Off

#### B-610 Rod Block Assembly



Sunnen B-610 Rod Block Assembly allows .3125" thru .4375" rod bolts to be removed and installed easily. Oversized block with extra depth and width allows installation of long style bolts used by Oldsmobile and others. Steel plate on bottom provides solid surface for removal of bolts and prevents damage to aluminum body.

#### Replacement Parts for B-610 Rod Block Assembly

Part No.	Description
B-613A	Replacement Plate
PG-2342A	Screws for Plate (4 required)

#### BP-99 Press Fluid

One Quart (.95 Liter)



For "topping off" hydraulic reservoir. Proper fluid level is shown on dip stick attached to filler cap. (See operating instructions for proper fluid description.)

For BP-10's after serial number 8799, order PLH-100 Hydraulic Oil.

*CAUTION: Use of hydraulic jack oil will cause press to malfunction.*

# HBS Resurfacer Accessories & Supplies

**Note: HBS systems are no longer in production.  
Supplies and accessories are still available.**

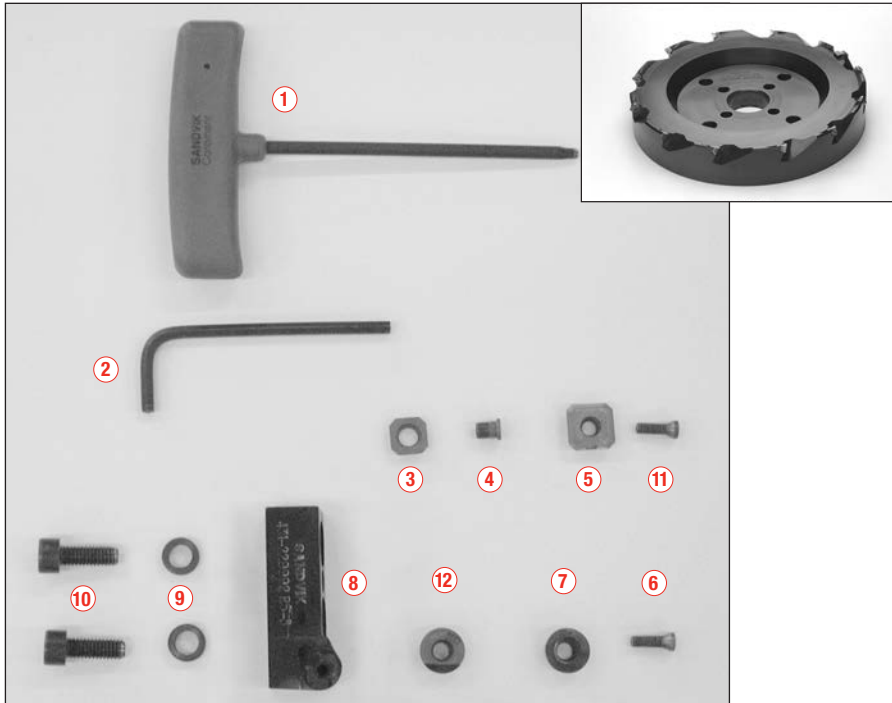

## HBS-1372 Cutter Plate Parts List

- |  |  |
|--|--|
| ① Torx Handle (T-15) HBS-13796   | ⑦ CBN Puck (1 required) TB-917A                        |
| ② Hex Wrench (3,5 mm) HBS-13797  | ⑧ CBN Cartridge (1 required) HBS-1379A                 |
| ③ Carbide Backing Shim (use 3,5 mm wrench) HBS-1376A   | ⑨ Flat Washer (2 required) HBS-13793                   |
| ④ Backing Shim Screw HBS-13795   | ⑩ Cartridge Torx Screw (2 required) HBS-13791 Torx #30 |
| ⑤ Coated Carbide Insert (Alum. Only) TB-916A (use T-15 wrench) Carbide Insert (Cast Iron & Alum. TB-918A (use T-17 wrench) | ⑪ Insert Screw (12 required) HBS1373A                  |
| ⑥ CBN Insert Screw (1 required) HBS-13794  | ⑫ PCD Puck (Alum. Only) TB-920A                        |

## Inserts for HBS-2872A Cutter Plate

14" diameter (356 mm) 16 cutter pockets, for .75" (19 mm) square inserts

**TB-896A** Carbide Insert, .75" (19 mm) square, .1875" (4,76 mm) thick, .106" (2,69 mm) cutting land. For aluminum applications.

**TB-897A** Carbide Insert, .75" (19 mm) square, .1875" (4,76 mm) thick, .106" (2,69 mm) cutting land. General Purpose.

**TB-899A** Carbide Insert, .75" (19 mm) square, .1875" (4,76 mm) thick, .062" (1,58 mm) cutting land. Diesel and General Purpose.

## HBS-2970 CBN Cutter Plate

Cutter Body, 14.25" (361,9 mm) diameter, 2 cutter pockets for .375" (9,52 mm) round inserts.

**TB-901A** CBN Insert, .375" (9,52 mm) round, .125" (3,17 mm) thick. Cast Iron only. (1 per pkg.) Must be ordered separately-not included with HBS-2970.

<b>HBS-2972-1</b>	Clamp Screw
<b>HBS-2972-2</b>	Clamp
<b>HBS-2972-3</b>	Screw for Backup Disk (shim)



# Thermal Cleaning Systems

## Accessories and Supplies

**Note: Thermal Cleaning Systems are no longer in production.  
Supplies and accessories are still available.**



### **Impeller Blades PB 14011C**

.25" thick (4-piece package)

### **PB 14012C**

.375" thick 2-3 times longer life  
(4-piece package)

### **Impeller Assembly PB 14000A**

For 2332/2304/2844

### **Impeller Housing PB 14003A**

For 2332/2304

### **TCS 26004A Filter Cartridge**

(1 each) Vac 600 uses 1  
cartridge; Vac 900 uses  
2 cartridges



### **TCS 24011**

Lynch Pins (5 per box)





# Online Ordering 24/7



Place your orders online @  
**www.sunnen.com**







A LEGACY OF EXCELLENCE SINCE 1924.

## WORLDWIDE

Our global manufacturing, distribution, and sales and service network allows us to deliver quality Sunnen solutions worldwide.

And our state-of-the-art Technical Services Centers allow our technical experts to develop innovative solutions to customer application challenges. The Centers also provide answers for customer questions and training for Sunnen representatives around the world.

### **SUNNEN PRODUCTS COMPANY WORLD HEADQUARTERS**

**St. Louis, MO – USA**  
Phone 1.314.781.2100  
Fax 1.314.781.2268  
Toll Free 1.800.325.3670  
Email [sunnen@sunnen.com](mailto:sunnen@sunnen.com)  
[www.sunnen.com](http://www.sunnen.com)

### **SUNNEN AG ENNETAACH – SWITZERLAND**

Phone +41 71 649 33 33  
Fax +41 71 649 33 34  
Email [sales@sunnen.eu](mailto:sales@sunnen.eu)  
[www.sunnen.eu](http://www.sunnen.eu)

### **SUNNEN ITALIA S.R.L. ARESE – ITALY**

Phone +39 02 383 4171  
Fax +39 02 383 417 50  
Email [sunnen@sunnenitalia.com](mailto:sunnen@sunnenitalia.com)  
[www.sunnenitalia.com](http://www.sunnenitalia.com)

### **SUNNEN SAS SACLAY – FRANCE**

Phone +33 169 30 00 00  
Fax +33 169 30 11 11  
Email [info@sunnen.fr](mailto:info@sunnen.fr)  
[www.sunnen.fr](http://www.sunnen.fr)

### **SUNNEN BENELUX BVBA KONTICH – BELGIUM**

Phone +32 38 80 2800  
Fax +32 38 44 3901  
Email [info@sunnen.be](mailto:info@sunnen.be)  
[www.sunnen.be](http://www.sunnen.be)

### **SUNNEN PRODUCTS LTD. HEMPSTEAD HERTS – UNITED KINGDOM**

Phone +44 1442 39 39 39  
Fax +44 1442 39 12 12  
Email [hemel@sunnen.co.uk](mailto:hemel@sunnen.co.uk)  
[www.sunnen.co.uk](http://www.sunnen.co.uk)

### **SUNNEN DO BRASIL LTDA. SÃO PAULO – BRASIL**

Phone +55 11 4177-3824  
Fax +55 11 4362-3083  
Email [sunnen@sunnen.com.br](mailto:sunnen@sunnen.com.br)  
[www.sunnen.com.br](http://www.sunnen.com.br)

### **SUNNEN POLSKA SP. Z O.O. WARSZAWA – POLAND**

Phone +48 22 814 34 29  
Fax +48 22 814 34 28  
Email [sunnen@sunnen.pl](mailto:sunnen@sunnen.pl)  
[www.sunnen.pl](http://www.sunnen.pl)

### **SUNNEN RUS LLC MOSCOW – RUSSIA**

Phone +7 495 258 43 43  
Fax +7 495 258 91 75  
Email [sunnen@sunnen-russia.ru](mailto:sunnen@sunnen-russia.ru)  
[www.sunnen.ru](http://www.sunnen.ru)

### **SUNNEN S.R.O. STRAKONICE – CZECH REPUBLIC**

Phone +420 383 376 317  
Fax +420 383 376 316  
Email [sunnen@sunnen.cz](mailto:sunnen@sunnen.cz)  
[www.sunnen.cz](http://www.sunnen.cz)

### **SHANGHAI SUNNEN MECHANICAL CO. LTD.**

**SHANGHAI – CHINA**  
Phone +86 21 5813 3990  
Fax +86 21 5813 2299  
Email [shsunnen@sunnensh.com](mailto:shsunnen@sunnensh.com)  
[www.sunnensh.com](http://www.sunnensh.com)

Sunnen reserves the right to change or revise specifications and product design in connection with any feature of our products contained herein. Such changes do not entitle the buyer to corresponding changes, improvements, additions, or replacements for equipment, supplies or accessories previously sold. Information contained herein is considered to be accurate based on available information at the time of printing. Should any discrepancy of information arise, Sunnen recommends that user verify the discrepancy with Sunnen before proceeding.