

Sunnen worldwide

Sunnen Products Company

St. Louis – USA
World Headquarters
Phone +1 314 781 21 00
Fax +1 314 781 06 92
sunnen@sunnen.com
www.sunnen.com

Sunnen AG

Ennetaach – Switzerland
European Technology Center
Phone +41 71 649 33 33
Fax +41 71 649 33 34
sales@sunnen.ch
www.sunnen.ch

Sunnen Italia S.r.l.

Ospiate di Bollate – Italy
Phone +39 02 383417 1
Fax +39 02 38341750
sunnen@sunnenitalia.com
www.sunnenitalia.com

Sunnen SAS

Saclay – France
Phone: +33 1 69 30 0000
Fax: +33 1 69 30 1111
info@sunnen.fr
www.sunnen.fr

Sunnen Products Ltd.

Hempstead Herts – UK
Phone +44 1442 393939
Fax +44 1442 391212
hemel@sunnen.co.uk
www.sunnen.co.uk

Sunnen Polska Sp. z o.o.

Warszawa – Poland
Phone +48 22 814 34 29
Fax +48 22 814 34 28
sunnen@sunnen.pl
www.sunnen.pl

Sunnen RUS »ООО«

Moscow – Russia
Phone +7 495 258 43 43
Fax +7 495 258 91 75
sunnen@sunnen-russia.ru
www.sunnen.ru

Sunnen s.r.o.

Strakonice – Czech Republic
Phone +420 383 376 317
Fax: +420 383 376 316
sunnen@sunnen.cz
www.sunnen.cz

Shanghai Sunnen

Mechanical Co. Ltd.
Shanghai – China
Phone +86 21 58133990
Fax +86 21 58132299
shsunnen@sunnensh.com
www.sunnensh.com

SUNNEN[®]

ABOVE AND BEYOND HONING

design: vegraphics.ch

X-SAG-HTD-E-C

Heavy Duty Tube Hone
HTD-W Series



Built for demanding applications



The Sunnen HTD-W Series

The series of the most successful tube hone system which runs at over 500 customers world-wide got a heavy duty extension. For highest demands, the leading tube hone system of Sunnen now provides a unique stock removal of 2'500 cm³/h and more. Two systems are available, the HTD-X300W and the HTD-X400W. Together with the state-of-the-art touch screen control and the enormous power, rough cold drawn tubes can be honed directly without expensive bore drilling.

The combination of the HTD system with Sunnen tooling, abrasive and coolant oil, guarantees optimum performance and perfect results. As an **all-inclusive supplier**, Sunnen takes full responsibility for the entire process.



Features and Benefits

- Large diameter range with stock removal rate of 2'500 cm³/h and more
- Automatic bore geometry correction
- Direct honing of rough parts, without expensive bore drilling
- 100% process control with tool overload protection
- The 3-axis function control manages stroke positions, motion control, stone feed, spindle speed and the cutting pressure guarantees the most favourable accuracy and bore geometry
- Repeat position of stroke within 0.1 mm during operation, independent of different stroke speeds
- Stroke speed variable (stroke rate adjustable in 0.1 m/min increments through operator interface adjustable during cycle)
- Size lock system with stone wear compensation
- Dwell and oscillation feature
- Spark out function
- All axes are electrical driven (efficiency up to 90%)
- Storage facility for over 900 programmed set-ups
- Spindle jog, short stroke
- Digital stroke position indicator
- Digital stroke speed indicator
- Digital spindle RPM readout
- Front stationary steady rest shaft support
- Tool lift for tool insertion and removal

Heavy Duty HTD-X300W	Variation of HTD-X400W	
Capacity <ul style="list-style-type: none"> • Stock Removal Power • I.D. Capacity • O.D. Capacity 	2'000 cm ³ / h (122 in ³ / h) 50 - 500 mm (2 - 20 in) 850 mm (33.5 in)	2'500 cm ³ / h (153 in ³ / h) 200 - 700 mm (8 - 27.6 in)
Spindle Drive System <ul style="list-style-type: none"> • AC-Spindle Motor • Spindle Speeds-Ininitely Variable • Quick coupling system to adapt the tool to the spindle drive 	22.0 kW 10 to 280 RPM CAMLOCK Size No 6	30.0 kW 10 to 165 RPM CAMLOCK Size No 11
Stroke System <ul style="list-style-type: none"> • Stroke Servo Motor • Speed Control • Stroking Speeds-Ininitely Variable • The spindle carriage runs by linear roller bearing on two hardened and ground linear way bars on the gear table (left side), automatically grease lubricated • Rack and pinion system guarantees most evenly carriage and tool movements 	14.0 kW / Gear Box Electronic - Variable 0.1 - 40 m / min	
Tool Feed System <ul style="list-style-type: none"> • Feed Servo Motor • The rotary tool feed is generated through servo motor and overlap gear system 	1.0 kW	
Computer Control <ul style="list-style-type: none"> • IPC (Industrial PC Control), Windows EMBEDDED control system screen size 15" • Languages E/D/I/F/S 		
Work Holding Fixture <ul style="list-style-type: none"> • 2 universal chain type V-block part fixtures for part weight up to 15'000 kg 		
Supply Requirements <ul style="list-style-type: none"> • Electrical Machine • Electrical Turbo Separator Filter unit • Pneumatics 	3 PNE 400 - 460 Volt / 50 / 60 Hz, 100 Amps. (80 Amps. on 460 V) 3 PNE 400 - 460 Volts / 50 / 60 Hz, 25 Amps. (22 Amps. on 460 V) 6 bar, 250 l / min to 1 / 2" ID thread	3 PNE 400 - 460 Volts / 50 / 60 Hz, 120 Amps. (100 Amps. on 460 V)
Lubrication System <ul style="list-style-type: none"> • Way Bearings • Rack and Pinion • Spindle Bearings • Gear Reducers 	Auto Forced Grease Auto Forced Grease Oil Bath Oil Bath	
Coolant System <ul style="list-style-type: none"> • Sump Pump • Supply Pump • Filter System Optional 	100 l / min External, 65 l / min External, Turbo Separator Centrifugal filter unit with integrated Oil Chiller or Customer Solution	
Safety Features CE Version:	1 Light Curtain on front of spindle table 1 Scanner System on front of work table 1 Light Curtain on backside of spindle table 1 Fence on backside of work table	
Paint <ul style="list-style-type: none"> • Silver Grey RAL 9006 / Dark Blue RAL 5002 		
Optional Features <ul style="list-style-type: none"> • Double stage tools option (roughing / finishing Tooling) • Taper bore option • Part rotary device • In-process gaging • Special applications can be addressed as required 		

Technical Specifications

HTD-X300W and HTD-X400W-Series Specifications	HTD-4X00W	HTD-6X00W	HTD-8X00W	HTD-10X00W	HTD-12X00W	HTD-14X00W
Maximum Bore Length	4'000 mm	6'000 mm	8'000 mm	10'000 mm	12'000 mm	14'000 mm
Maximum Stroke Length	4'900 mm	6'900 mm	8'700 mm	10'700 mm	12'500 mm	14'500 mm
No. of Steady Rests	0	1	2	2	3	3
Overall Length *	13'400 mm	17'400 mm	21'400 mm	25'400 mm	29'400 mm	33'400 mm
Overall Width	1'700 mm	1'700 mm	1'700 mm	1'700 mm	1'700 mm	1'700 mm
Spindle Center Height to Floor	1'200 mm	1'200 mm	1'200 mm	1'200 mm	1'200 mm	1'200 mm
Height	2'220 mm	2'220 mm	2'220 mm	2'220 mm	2'220 mm	2'220 mm
Weight	8'000 kg	10'000 kg	11'000 kg	13'000 kg	15'000 kg	17'000 kg

* Easy to extend stroke length on customers site (modules of 4 Meters)

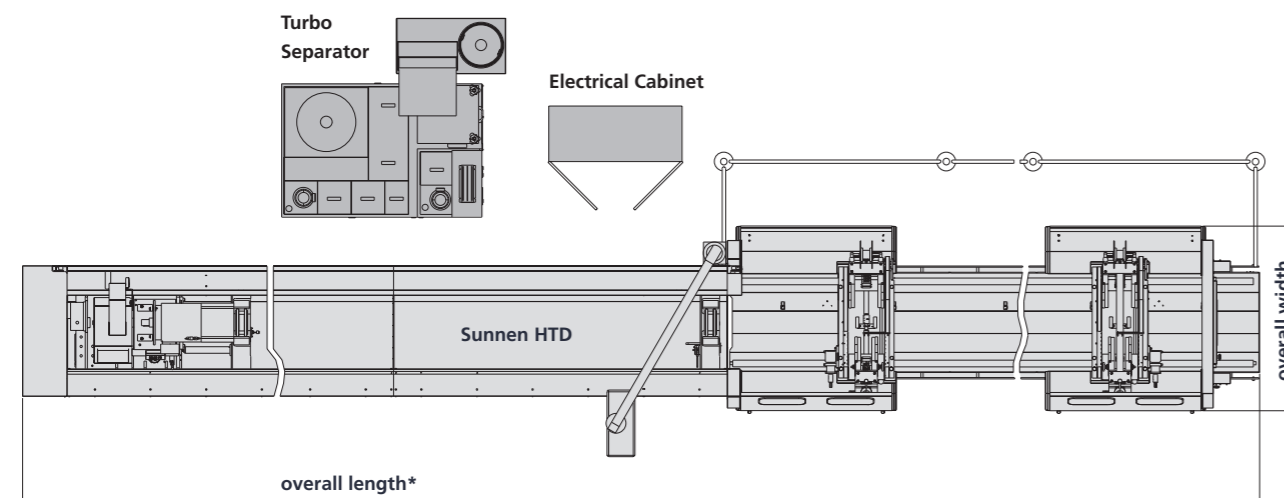

NOTE: Sunnen reserves the right to change or revise specifications and product design in connection with any feature of our products contained herein. Such changes do not entitle the buyer to corresponding changes, improvements, additions, or replacements for equipment, supplies or accessories previously sold. Information contained herein is considered to be accurate based on available information at the time of printing. Should any discrepancy of information arise, Sunnen recommends that user verify the discrepancy with Sunnen before proceeding in any bore sizing and finishing operation.

Main Focus:

Cylinder Liners, Hydraulic Cylinders, Extrusion Cylinders, Aircraft Components, Compressor Components

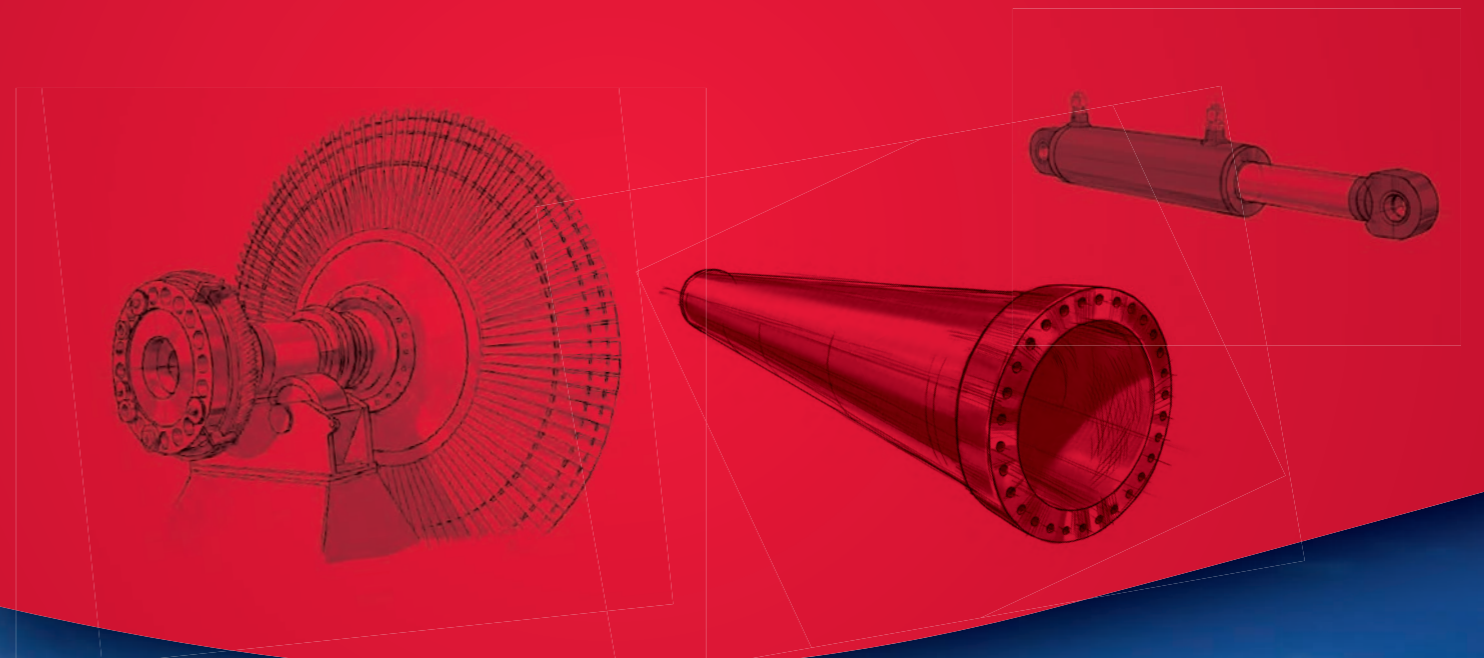

Oil & Gas Industry



The **unique touch screen control** of
Sunnens guarantees lowest manufacturing costs per part due to:

Automatic bore geometry correction
 The system indicates high and low spots and corrects the geometry with appropriate short strokes without operator intervention.

Easy set-up
 All parameters are stored and the system recommends the required tool, sets the spindle speed and all necessary cycle parameters. A new set-up can be made within 2 minutes, step-by-step.

Tool overload protection
 The 100% control of the process ensures optimal stock removal and protection of the tool.

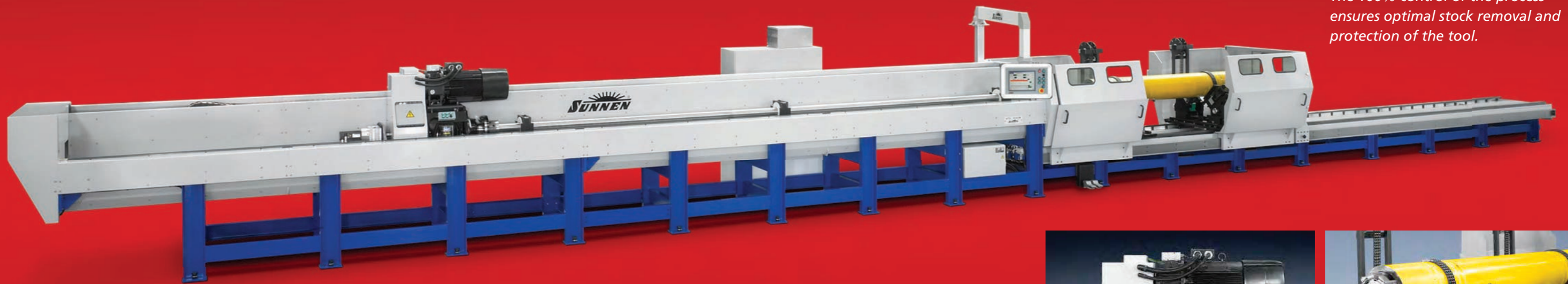

Multi-stone GH Tool
 ø 12.7 - 450 mm
 3 - 10 abrasive stones in use

Multi-stone 2C-Shell Tool
 for large diameters



The power drive
 Honed a typical cylinder for off-shore or similar with diameter 250 mm (10 in.), 6000 mm (236 in.) length and 0.5 mm (0.02 in.) stock removal in less than 30 minutes.



The flexible fixture system
 Standard or with optional part rotary device, the HTD-W can be equipped according to tube shapes and customer needs.